

# LOVOL

CONSTRUCTION EQUIPMENT

**ROBUST RELIABLE SUPPORTED**

## FR510E2-HD



- Cummins Engine - 298kw/2000 RPM
- Bucket Capacity - 2.5m<sup>3</sup>
- Operating Weight - 51 000 kg
- Standard Piped for Attachment

**POWERED BY**

**DURA**  
EQUIPMENT  
**SALES**

# Technical Specifications

## ENGINE

Model	Cummins QSM11
Type	Diesel
Number of Cylinders	6
Bore	125mm
Stroke	147mm
Horsepower	298kW
Rated RPM	2000 RPM

## HYDRAULICS

Main Pump Type	Kawasaki
Main Valve	Kawasaki
Swing Motor	Kawasaki
Boom Cylinder	Hengli
Bore	110mm
Stroke	1570mm
Diameter	160mm
Stick Cylinders	Hengli
Bore	130mm
Stroke	1900mm
Diameter	190mm
Bucket Cylinder	Hengli
Bore	120mm
Stroke	1315mm
Diameter	170mm
Travel Circuit	34.3 Mpa
Implement Circuit	37.3 Mpa
Swing Circuit	26.8 Mpa
Pilot Circuit	3.9 Mpa
Hydraulic Piping	Standard
Pump Flow	760L/min
Pump Pressure	34.3 Mpa

## UNDERCARRIAGE

Frame	X-Type
Rail Distance	2740mm
Track Width of Shoe	600mm
Undercarriage Width	3340mm
Track Length	5498mm
Number of Shoes	50
Number of Carrier Rollers	2
Number of Track Rollers	9

## DRIVE

Travel Motor	Nabtesco
Maximum Travel Speed	5.3km/h
Steering Control	2 Levers/ Pedals
Drive Method	Hydrostatic
Max Pressure	34.3 Mpa

## SWING SYSTEM

Drive Method	Hydrostatic
Swing Speed	7.8 r/min
Swing Circle Lubrication	Grease
Swing Lock	Oil-disc Brake
Swing Reduction	Planetary Gear
Max System Pressure	34.3 Mpa

## FRONT LINKAGE

Bucket Type	General Purpose/ Rock Bucket
Bucket Breakout Force	310KN (31310kg)
Bucket Capacity	2.5m <sup>3</sup>
Bucket Options	As Per Application
Boom Length	6500mm
Stick Length	2550mm

## SERVICE REFILL CAPACITIES

Fuel Tank	670L
Cooling System	40L
Engine Oil	38L
Swing Motor	10.5L
Final Drive	15 x 2 L
Hydraulic Tank	370L

# Dimension Specifications

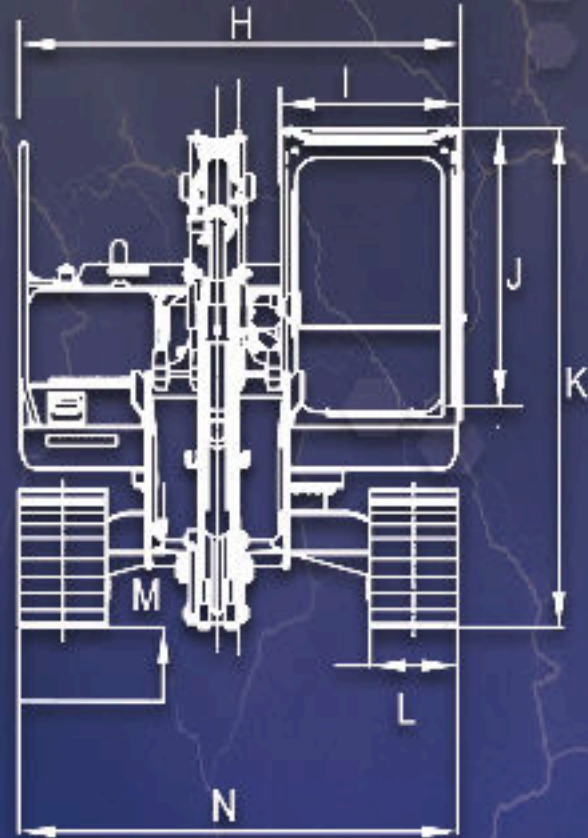
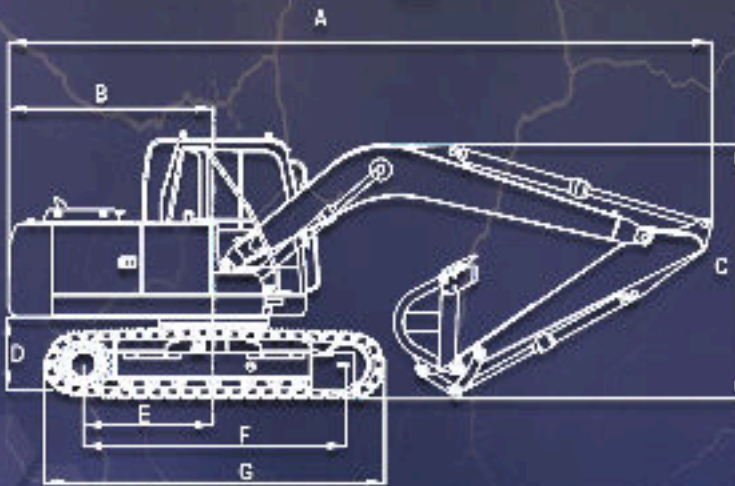

<b>Overall Dimensions (mm)</b>	<b>6500/2505</b>
A) Overall Length	11668mm
B) Swing Radius	3800mm
C) Height of Boom	4100mm
D) Counterweight Clearance	1237mm
E) Centre to Middle of Track Frame	2211mm
F) Distance of Track on Ground	4430mm
G) Undercarriage Length	5498mm
H) Overall Width of body	3340mm
I) Cab Width	1000mm
J) Cab Height	1700mm
K) Height to Top of Cab	3260mm
L) Track Shoe Width	600mm
M) Ground Clearance	550mm
N) Undercarriage Width	3340mm

<b>Working Ranges (mm)</b>	<b>6500/2505</b>
O) Max Cutting Height	10715mm
P) Max Dumping Height	7156mm
Q) Max Digging Depth	6580mm
R) Centre to Max Digging Depth	10896mm



# WARRANTY

1 Year Unlimited Hours Warranty or 24 Months / 5000 Hours Warranty  
6 Months / 1000 Hours Electrical Warranty  
4 Complimentary Services (250/500/750/1000 Hours)



## MACHINE

Quality **Robust, Reliable, Supported** equipment.

Basic mechanical operation with basic electronics for easy maintenance.

Various attachments are available for your specific needs.

We guarantee 24/7 Backup and Support from Dura Equipment Sales.

We host an on-site state-of-the-art workshop for repairs.

On-site support is rendered by qualified field technicians.

Full mine spec machine.

Dura Equipment Sales is the sole agent for Lovol Construction Equipment in South-Africa.



We guarantee full parts availability on all Lovol Construction Equipment. Dura Equipment Sales is the sole provider for Lovol Construction Equipment.

Gauteng: (Head Office)

+27 (0) 11 918 4760

[admin@durasales.co.za](mailto:admin@durasales.co.za)

46 Viewpoint rd Bartlett Boksburg

GPS: 29 10' 28.95" S 28 15'04.39"

North West:

+27 (0) 79 874 5458

[marketing@durasales.co.za](mailto:marketing@durasales.co.za)

8 Wordsworth Ave

Orkney, North West

Western Cape:

+27 (0) 21 988 6618

[capeadmin@durasales.co.za](mailto:capeadmin@durasales.co.za)

30 Kiaat street, Kraaifontein Industrial,

Kraaifontein, Cape Town

KwaZulu-Natal / Richards Bay:

+27 (0) 82 576 6068

[marketing@durasales.co.za](mailto:marketing@durasales.co.za)

122 Alumina Allee, Alton,

Richards Bay

POWERED BY



All dimensions are shown in millimetres, unless stated between brackets. Under our policy of continuous improvements, we reserve the right to change specifications and design without prior notice. Photographs features in this brochure may include optional equipment.

Terms and Conditions Apply

[www.durasales.co.za](http://www.durasales.co.za)

**WEICHAI**