

LOVOL

CONSTRUCTION EQUIPMENT

ROBUST RELIABLE SUPPORTED

FR700F



- Weichai Engine - 566kw/1900RPM
- Bucket Capacity - 4.4m³
- Operating Weight - 69 000 kg
- Standard Piped for Attachment

POWERED BY

DURA
EQUIPMENT
SALES

Technical Specifications

ENGINE

Model	WEICHAI WP15H
Type	Diesel
Number of Cylinders	6
Bore	140mm
Stroke	166mm
Horsepower	566kW
Rated RPM	1900 RPM

DRIVE

Travel Motor	KYB
Maximum Travel Speed	4.5km/h
Steering Control	2 Levers/Pedals
Drive Method	Hydrostatic
Max Pressure	37.3 Mpa

HYDRAULICS

Main Pump Type	Linde
Main Valve	Linde
Swing Motor	Linde
Boom Cylinder	Hengli
Bore	190mm
Stroke	1725mm
Diameter	130mm
Stick Cylinders	Hengli
Bore	200mm
Stroke	2080mm
Diameter	140mm
Bucket Cylinder	Hengli
Bore	190mm
Stroke	1470mm
Diameter	130mm
Travel Circuit	34.3 Mpa
Swing Circuit	31.5 Mpa
Pilot Circuit	3.9 Mpa
Hydraulic Piping	Standard
Pump Flow	1020L/min
Pump Pressure	37.3 Mpa

SWING SYSTEM

Drive Method	Hydrostatic
Swing Speed	6.8 r/min
Swing Circle Lubrication	Grease
Swing Lock	Oil-disk Brake
Swing Reduction	Planetary Gear
Max System Pressure	34.3 Mpa

FRONT LINKAGE

Bucket Type	General Purpose/ Rock Bucket
Bucket Breakout Force	374KN (37774kg)
Bucket Capacity	4.4m ³
Bucket Options	As per Application
Boom Length	6800mm
Stick Length	2800mm

UNDERCARRIAGE

Frame	X-Type Adjustable
Rail Distance	2810mm/3350mm
Track Width of Shoe	600mm
Undercarriage Width	3410/3950mm
Track Length	5710mm
Number of Shoes	52
Number of Carrier Rollers	3
Number of Track Rollers	9

SERVICE REFILL CAPACITIES

Fuel Tank	800L
Cooling System	60L
Engine Oil	52L
Swing Motor	10.5 x 2L
Final Drive	15 x 2L
Hydraulic Tank	600L

Dimension Specifications

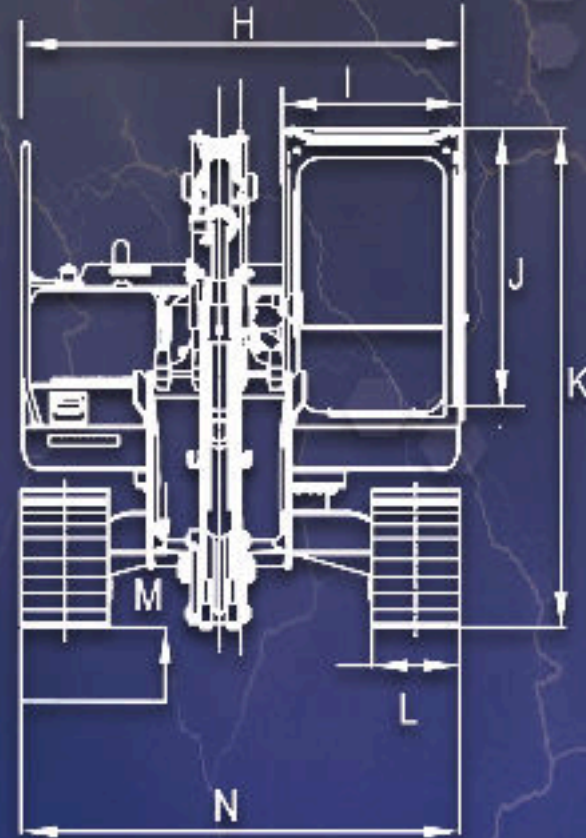
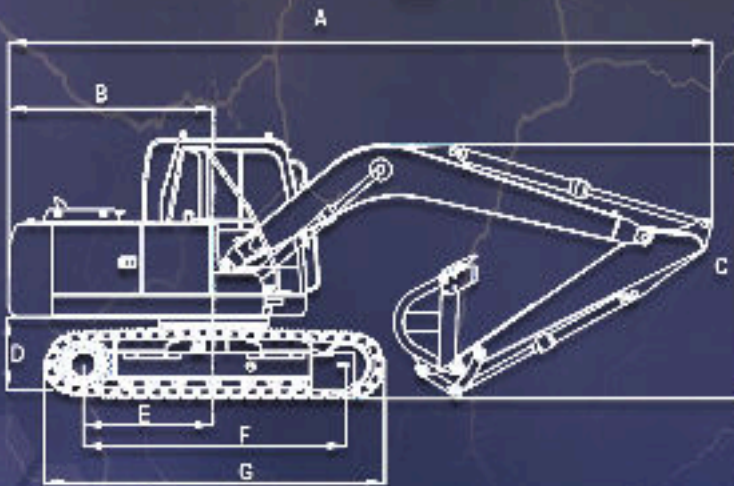

Overall Dimensions (mm)	6500/2450
A) Overall Length	12550mm
B) Swing Radius	4120mm
C) Height of Boom	4750mm
D) Counterweight Clearance	1580mm
E) Centre to Middle of Track Frame	2375mm
F) Distance of Track on Ground	4750mm
G) Undercarriage Length	5170mm
H) Overall Width of body	3350mm
I) Cab Width	1023mm
J) Cab Height	1732mm
K) Height to Top of Cab	3600mm
L) Track Shoe Width	600mm
M) Ground Clearance	880mm
N) Undercarriage Width	3240mm

Working Ranges (mm)	6500/2450
O) Max Cutting Height	11300mm
P) Max Dumping Height	7320mm
Q) Max Digging Depth	7170mm
R) Centre to Max Digging Depth	11760mm

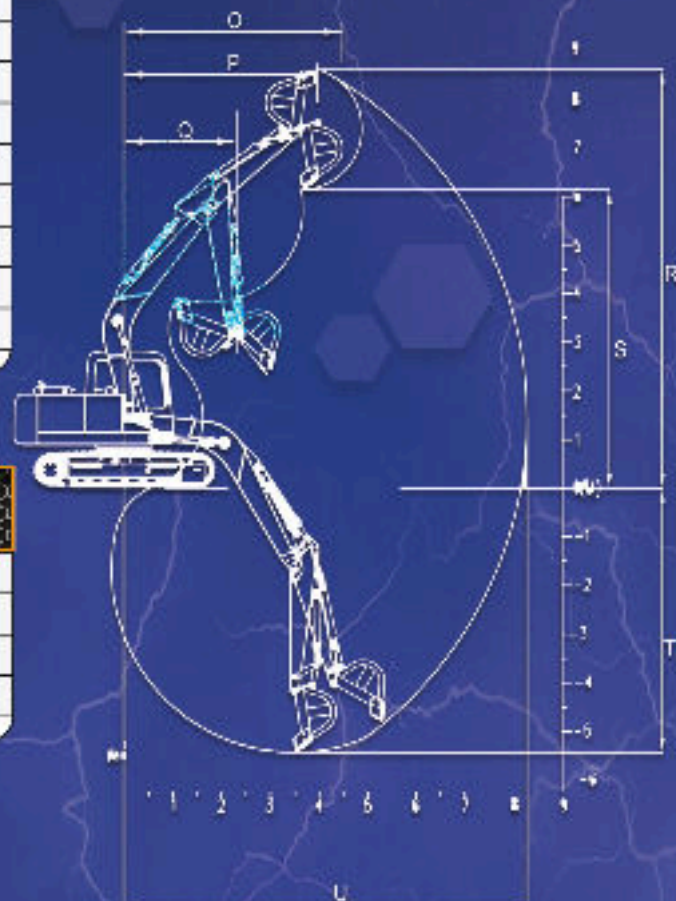

WARRANTY

1 Year Unlimited Hours Warranty or 24 Months / 5000 Hours Warranty
6 Months / 1000 Hours Electrical Warranty
4 Complimentary Services (250/500/750/1000 Hours)



MACHINE

Quality **Robust, Reliable, Supported** equipment.

Basic mechanical operation with basic electronics for easy maintenance.

Various attachments are available for your specific needs.

We guarantee 24/7 Backup and Support from Dura Equipment Sales.

We host an on-site state-of-the-art workshop for repairs.

On-site support is rendered by qualified field technicians.

Full mine spec machine.

Dura Equipment Sales is the sole agent for Lovol Construction Equipment in South-Africa.



We guarantee full parts availability on all Lovol Construction Equipment. Dura Equipment Sales is the sole provider for Lovol Construction Equipment.

Gauteng: (Head Office)

+27 (0) 11 918 4760

admin@durasales.co.za

46 Viewpoint rd Bartlett Boksburg

GPS: 29 10' 28.95" S 28 15'04.39"

North West:

+27 (0) 79 874 5458

marketing@durasales.co.za

8 Wordsworth Ave

Orkney, North West

Western Cape:

+27 (0) 21 988 6618

capeadmin@durasales.co.za

30 Kiaat street, Kraaifontein Industrial,

Kraaifontein, Cape Town

KwaZulu-Natal / Richards Bay:

+27 (0) 82 576 6068

marketing@durasales.co.za

122 Alumina Allee, Alton,

Richards Bay

POWERED BY



All dimensions are shown in millimetres, unless stated between brackets. Under our policy of continuous improvements, we reserve the right to change specifications and design without prior notice. Photographs features in this brochure may include optional equipment.

Terms and Conditions Apply

www.durasales.co.za

WEICHAI