

DIAMOND12

Single Auger



Standard Features

- Single Auger/ 33,5 rpm @ 540 rpm tractor PTO Speed.
- Heavy Duty Planetary Gearbox 16,13 : 1 ratio.
- 3CR12 Stainless Steel Inner Liners.
- Dinamica Generale DG400 Standard Scale + 4 load cells.
- PTO Drive shaft, A8.
- Anti-Overflow ring.
- 380/55 R16.5 Tyres + 80 x 80 Axle, 8 Stud.

Optional Extras

- Dinamica Generale DG500/DG600 Smart Scale.
- Magnet on discharge conveyor.
- Stationary Option



Specifications

Cubic meter:	12m³
Weight Empty:	3900kg
Maximum Load: (Dependant on the density of the ration).	4500kg
Recommended Tractor Size with Hydraulics:	80kW

Material

Side wall thickness: (6mm Mild Steel + 1.6mm Stainless Steel).	7.6mm
Floor thickness:	20mm

Auger

Cutting Blades.	13
Pick-up Width.	940mm
Flight thickness Middle & Top	12mm
Flight + S/Steel Roundbar.	16mm
Flight thickness Bottom Flight + S/Steel Roundbar.	16mm

Dimensions

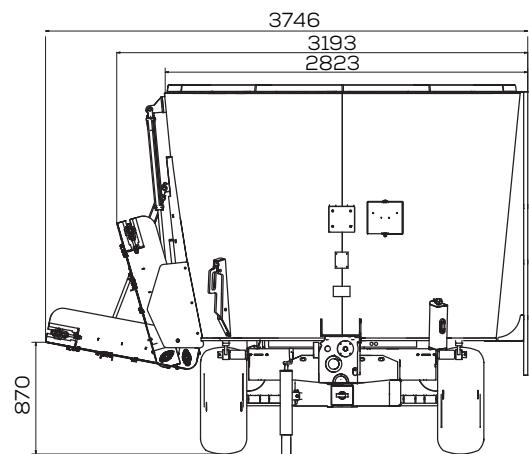
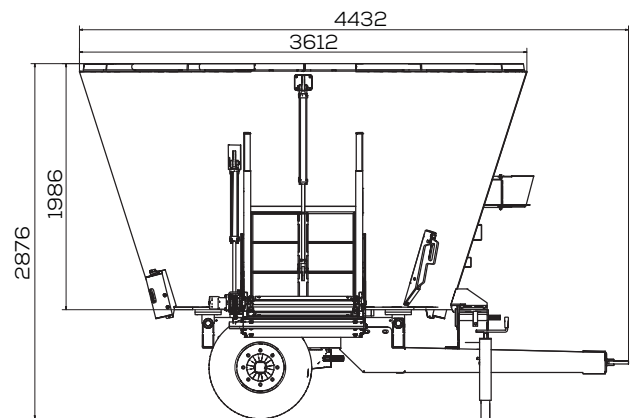

Unleash the
power of precision

