

DIAMOND16

Twin Auger



Standard Features

- Twin Auger/ 21, rpm @ 540 rpm tractor PTO Speed.
- Heavy Duty Planetary Gearbox 25.89 : 1 ratio.
- 3CR12 Stainless Steel Liners inside the bin.
- Dinamica Generale DG400 Standard Scale + 4 load cells.
- PTO Drive shaft, A8.
- Anti-Overflow ring.
- 315/80 R22.5 Tyres + 90 x 90 Axle, 10 Stud.

Optional Extras

- Dinamica Generale DG500/DG600 Smart Scale.
- Magnet on discharge conveyor.
- Stationary Option



Specifications

Cubic meter:	16m³
Weight Empty:	6700kg
Maximum Load: (Dependant on the density of the ration).	6000kg
Recommended Tractor Size with Hydraulics:	90kW

Material

Side wall thickness: (6mm Mild Steel + 1.6mm Stainless Steel).	7.6mm
Floor thickness:	20mm

Auger

Cutting Blades (13 per auger)	26
Serrated Ninja Blades (5 per auger)	10
Pickup Flight Width	840mm
Flight thickness Middle & Top Flight + S/Steel Roundbar	12mm
Flight thickness Bottom Flight + S/Steel Roundbar	16mm

Dimensions

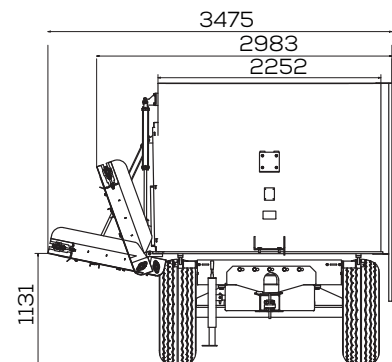
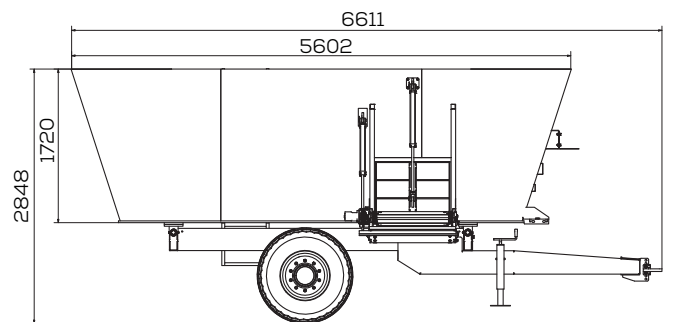

Unleash the
power of precision

