

DIAMOND⁹

Single Auger



Standard Features

- Single Auger/ 33,5 rpm @ 540 rpm tractor PTO Speed.
- Heavy Duty Planetary Gearbox 16,13 : 1 ratio.
- 3CR12 Stainless Steel Inner Liners.
- Dinamica Generale DG400 Standard Scale + 4 load cells.
- PTO Drive shaft, A6.
- Anti-Overflow ring.
- 10.5/R16 Tyres (14 Ply) + 70 x 70 Square Axle, 6 Stud.

Optional Extras

- Dinamica Generale DG500/DG600 Smart Scale.
- Magnet on discharge conveyor.
- Stationary Option



Specifications

Cubic meter:

9m³

Weight Empty:

3500kg

Maximum Load:

3000kg

(Dependant on the density of the ration).

Recommended Tractor Size with Hydraulics:

70kW

Material

Side wall thickness:

7.6mm

(6mm Mild Steel + 1.6mm Stainless Steel).

Floor thickness:

16mm

Auger

Cutting Blades.

13

Pick-up Width.

840mm

Flight thickness Middle & Top

Flight + S/Steel Roundbar.

12mm

Flight thickness Bottom Flight + S/Steel Roundbar.

16mm

Dimensions

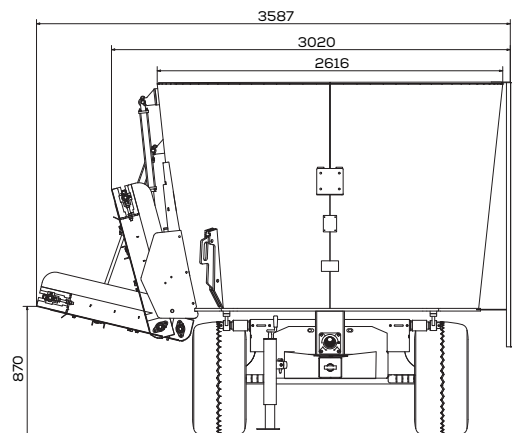
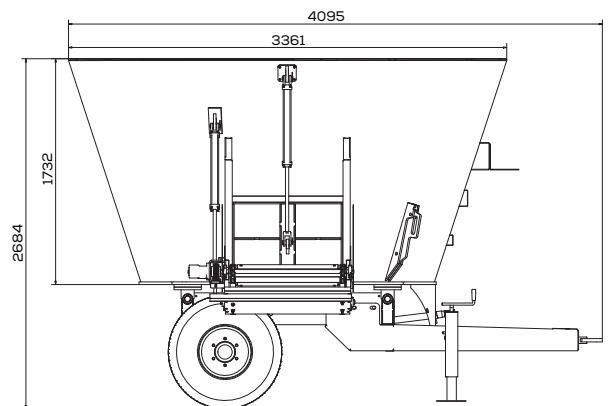

Unleash the
power of precision

