

Engine	Cummins 6LTAA9.3
Gross Power	162 kW (220 hp) @ 2,200 rpm
Net Power	154 kW (209 hp) @ 2,200 rpm
Operating Weight	17,100 kg
Standard Bucket Size	3 m <sup>3</sup>
Standard Breakout Force	173 kN
Standard Dump Clearance	3,100 mm

# 856H WHEEL LOADER



TOUGH WORLD. TOUGH EQUIPMENT.

# 856H SPECIFICATIONS >>>

ENGINE	
Emission Regulation	Tier 2 / Stage II
Make	Cummins
Model	6LTAA9.3
Gross Power	162 kW (220 hp) @ 2,200 rpm
Net Power	154 kW (209 hp) @ 2,200 rpm
Peak Torque	940 N · m
Displacement	9.3 L
Number of Cylinder	6
Aspiration	Turbocharged & Air-to-air intercooled

TRANSMISSION	
Transmission Type	Countershaft, power shift
Torque Converter	Single stage, three elements
Maximum Travel Speed, fwd	39.7 km/h
Maximum Travel Speed, rev	23.9 km/h
Number of Speed, fwd	4
Number of Speed, Rev	3

AXLES	
Differential Front Type	Limited slip
Differential Rear Type	Limited slip
Axle Oscillation	±12°

STEERING	
Steering Configuration	Articulated
Steering Relief Pressure	20.7 MPa

BRAKES	
Service Brake Type	Wet discs brake
Service Brake Actuation	Hydraulic
Parking Brake Type	Manual electronic control
Parking Brake Actuation	Hydraulic

HYDRAULIC SYSTEM	
Main Pump Type	Gear + Piston
Main Relief Pressure	20.7 MPa
Raise	5.7 s
Dump Time	1.3 s
Float Down Time	3 s
Fastest Total Cycle Time	10 s

LOADER ARM PERFORMANCE	
Tipping Load - Straight	12,500 kg
Tipping Load - Full Turn	10,800 kg
Bucket Breakout Force	173 kN
Maximum Dump Angle at Full Height	45°
Dump Clearance at Full Height Discharge	3,100 mm
Dump Reach at Full Height Discharge	1,126 mm
Maximum Hinge Pin Height	4,159 mm
Maximum Digging Depth, Bucket Level	40 mm
Bucket Rollback at Ground Level	44°
Bucket Rollback at Carry	49°
Bucket Rollback at Maximum Height	58.5°

BUCKET PERFORMANCE	
Reference Bucket	3.0 m <sup>3</sup>

DIMENSIONS	
Length with Bucket Down	8,253 mm
Width Over Tires	2,750 mm
Wheelbase	3,320 mm
Wheel Tread	2,150 mm
Ground Clearance	431 mm
Turn Angle, Either Side	38°
Rear Angle of Departure	27°
Turning Radius, Outside of Tire	6,205 mm
Turning Radius, Center of Tire	5,896 mm
Turning Radius, Bucket Carry	6,914 mm

TIRES	
Tire Size	23.5 - 25

OPERATING WEIGHTS	
Operating Weight	17,100 kg

SERVICE CAPACITY	
Fuel Tank	300 L
Engine Oil	18 L
Cooling System	42 L
Hydraulic System	236 L
Transmission and Torque Converter	45 L
Axles, Each	44 L

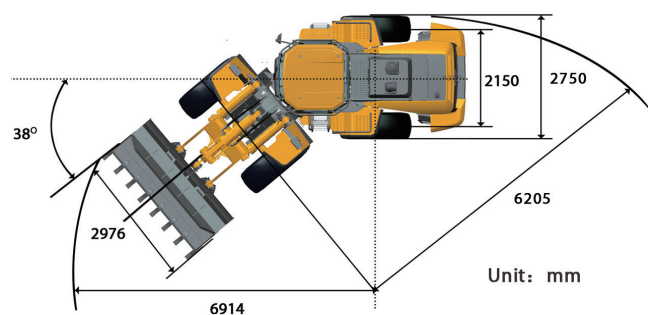
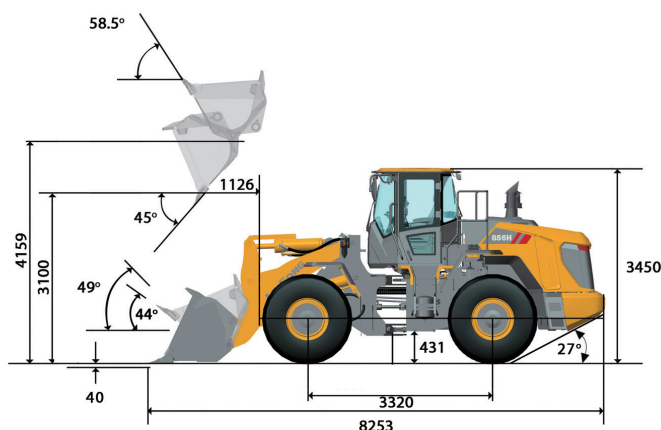

Unit: mm

## Contact us:

011-306-0700

elb@elbquip.co.za

www.elbequipment.co.za

06/2014 Designed by LiuGong

Specifications and designs are subject to change without notice. Machines shown may include optional equipment.