

HYDAC INTERNATIONAL

Axial Piston Pump
PPV100M

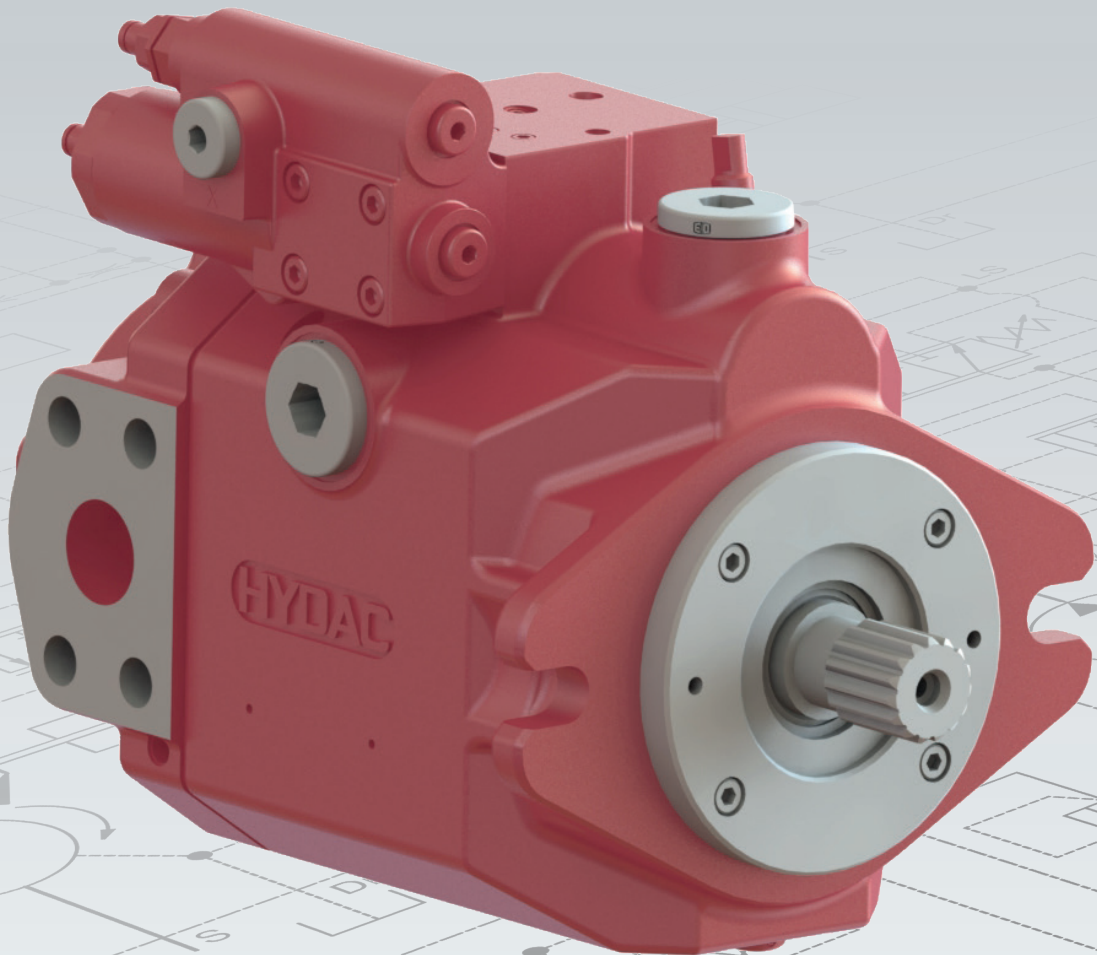

EXCLUSION OF LIABILITY

This document was compiled to the best of our knowledge. Nevertheless and despite the greatest care, it is possible that it may contain errors. Therefore please understand that in the absence of any provisions to the contrary hereinafter our warranty and liability – for any legal reasons whatsoever – are excluded in respect of the information in this document. In particular, we shall not be liable for lost profit or other financial loss.

This exclusion of liability does not apply in cases of intent or gross negligence. Moreover, it does not apply to defects which have been deceitfully concealed or whose absence has been guaranteed, nor in cases of culpable harm to life, physical injury and damage to health. If we negligently breach any material contractual obligation, our liability shall be limited to foreseeable damage. Claims due to the product liability shall remain unaffected.

DESCRIPTION

The axial piston pumps in the PVV100M series work according to the swash plate principle. The PPV100M series is designed for open loop hydraulic circuits in modern mobile machines.

The comprehensive and modular range of controllers enables continuous and energy-saving adjustment of the displacement in the PPV100M series.

A wide selection of through drives are available for the build-up of multiple pump combinations.

The PPV100M series can also be equipped with an extensive range of sensors.

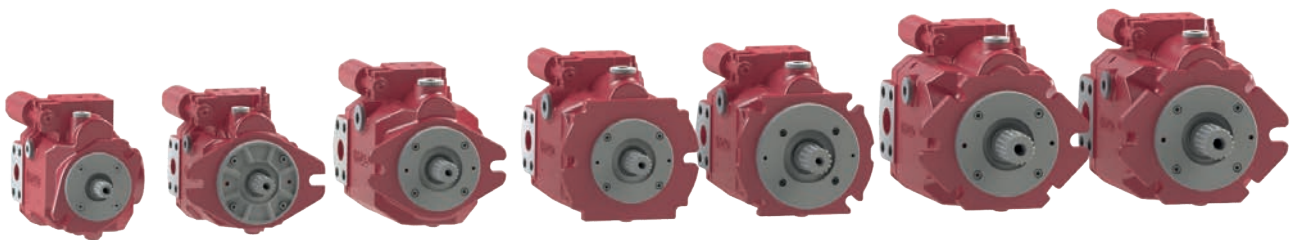

FEATURES

- Displacement from 18 cm³/rev to 100 cm³/rev in 6 closely stepped pump sizes
- High max. nominal pressure of 315 bar and maximum pressure of 350 bar for safety reserves and a compact actuator system
- High maximum rotational speeds, adjusted to the requirements of modern mobile machines
- Mechanical adjustment of maximum displacement ($V_{g_{max}}$)
- Can be mounted in any mounting position
- Long service life due to robust shaft bearing
- Possible external forces can be absorbed by the pump drive shaft
- Compact design
- Modular range of controllers
- Direct connection of sensors as option
- Also available with through drive
- Low net weight to save energy and for greater payload of the mobile machine
- High permitted drive and through-drive torque for more pressure / flow rate in multi-pump combinations

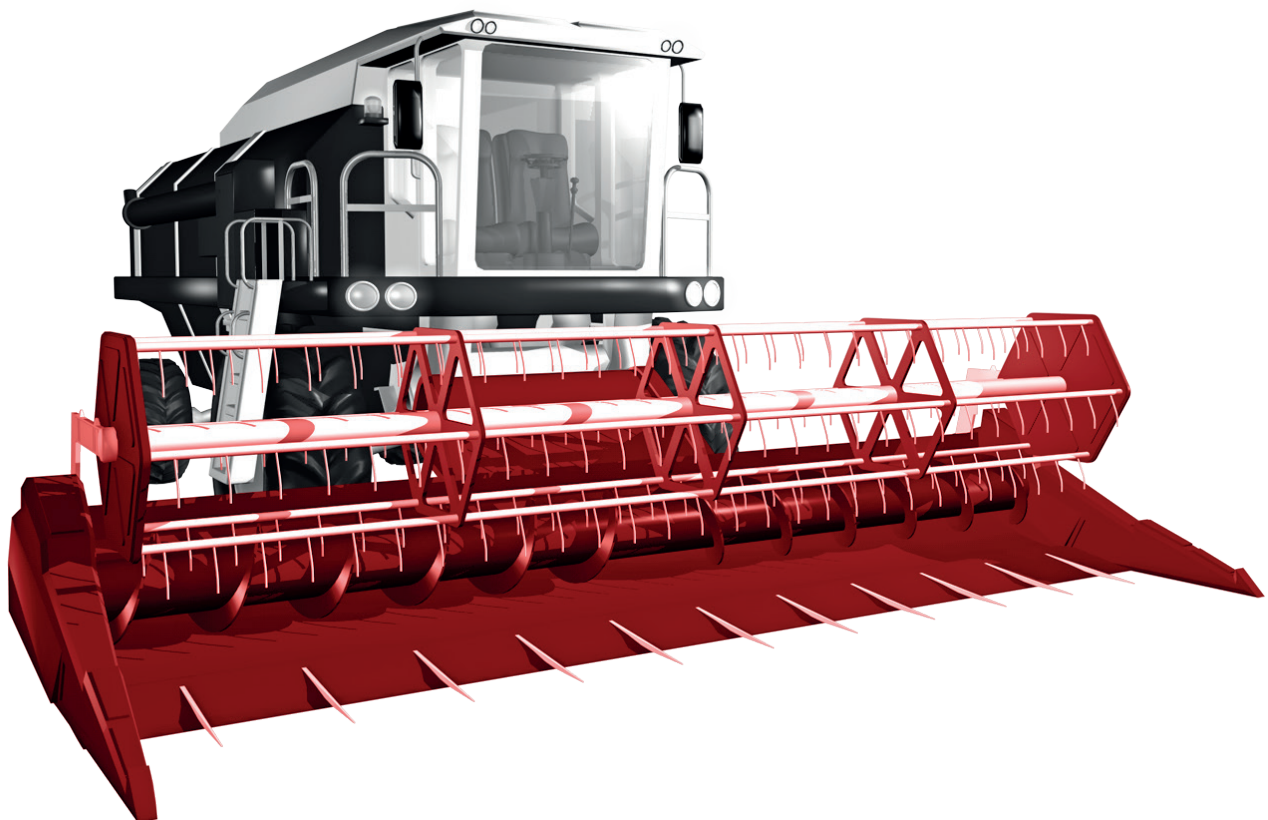

FIELDS OF APPLICATION

- Structural and civil engineering
- Agriculture and forestry
- Special-purpose vehicles
- Lorry superstructures
- Industrial trucks / hoisting equipment
- Municipal machines
- Maritime applications
- Machine and system engineering
- Mining
- Offshore applications
- Oil and gas

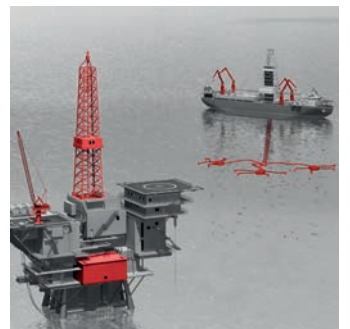

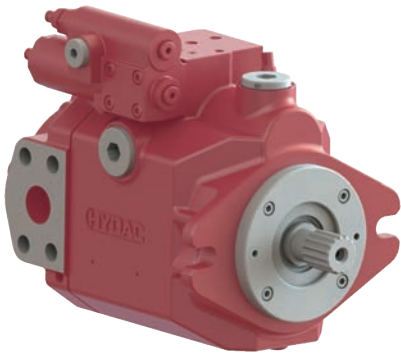

AXIAL PISTON PUMP FOR OPEN LOOP CIRCUITS PPV100M

Ordering code	1.1	PPV100M	7 - 8
<hr/>			
Technical information	2.1	Specifications	9 - 12
	2.2	Max. permissible drive and through drive torques	
	2.3	Pump combinations PPV100M and through drives	
	2.4	Seals	
	2.5	Filtration	
	2.6	Operating fluids	
	2.7	Temperature and viscosity range	
	2.8	Adjustment notes	
	2.9	Installation notes	
<hr/>			
Control options	3.1	Pressure control P	13 - 16
	3.2	Pressure remote control PR	
	3.3	Load-sensing control LS / LS0	
	3.4	Electrical displacement control ED	
	3.5	Electrical displacement control and pressure control EDP	
	3.6	Electrical displacement control and pressure remote control EDPR	
	3.7	Electrical displacement control and load-sensing control EDLS / EDLS0	
	3.8	Specific characteristics of the ED / EDP / EDPR / EDLS / EDLS0 control	
<hr/>			
Performance data	4.1	PPV100M18	17 - 22
	4.2	PPV100M28	
	4.3	PPV100M45	
	4.4	PPV100M63	
	4.5	PPV100M85	
	4.6	PPV100M100	
<hr/>			
Dimensions	5.1	PPV100M18	23 - 54
	5.2	PPV100M28	
	5.3	PPV100M45	
	5.4	PPV100M63	
	5.5	PPV100M85 / PPV100M100	
	5.6	Connectors for sensors	
<hr/>			

ORDERING CODE

PPV100M45 R - LS - B2 S - N V - 0 0 0 XX - YYYY

1.1 PPV100M

Axial piston pump

Medium heavy duty series
Open circuit

Size

18	18 cm ³ /rev
28	28 cm ³ /rev
45	45 cm ³ /rev
63	63 cm ³ /rev
85	85 cm ³ /rev
100	100 cm ³ /rev

Direction of rotation

R	clockwise rotation
L	anti-clockwise rotation

Control

P	pressure control
PR	remote pressure control
LS	load-sensing control (without internal LS drain)
LS0	load-sensing control (with internal LS drain)
ED	electrical displacement control
EDP	electrical displacement control and pressure control
EDPR	electrical displacement control and pressure remote control
EDLS	electrical displacement control and load-sensing control (without internal LS drain)
EDLS0	electrical displacement control and load-sensing control (with internal LS drain)

Voltage

12	12 volts
24	24 volts

Mounting flange

A2	SAE A, 2-hole (only 18 cm ³ /rev)
B2	SAE B, 2-hole (only 28, 45 and 63 cm ³ /rev)
C4	SAE C, 4-hole (only 63 cm ³ /rev)
C5	SAE C, 2/4-hole combination flange (only 85 and 100 cm ³ /rev)

Drive shaft

S	SAE splined shaft (standard)	
	18 cm ³ /rev:	11T-16/32DP
	28 cm ³ /rev:	13T-16/32DP
	45 cm ³ /rev:	15T-16/32DP
	63 cm ³ /rev with mounting flange B2:	15T-16/32DP
S1	SAE splined shaft	
	45 cm ³ /rev:	13T-16/32DP
	85 and 100 cm ³ /rev:	14T-12/24DP
T	SAE splined shaft (for increased drive torque)	
	18 cm ³ /rev:	11T-16/32DP
	28 cm ³ /rev:	13T-16/32DP
	45 cm ³ /rev:	15T-16/32DP
	63 cm ³ /rev with mounting flange B2:	15T-16/32DP
T1	SAE splined shaft	
	45 cm ³ /rev:	13T-16/32DP
	85 and 100 cm ³ /rev:	14T-12/24DP

ORDERING CODE

PPV100M45 R - LS = B2 S - N V - 0 0 0 XX - YYYY

Through drive options

N	single pump prepared for through drive, side ports
A	through drive SAE A 9T, 16/32 DP
AB	through drive SAE A 11T, 16/32 DP
AI	through drive SAE A 11T, 16/32 DP (only 45 and 63 cm ³ /rev – for secondary pump with 45° diagonal flange)
B	through drive SAE B 13T, 16/32 DP
BB	through drive SAE B 15T, 16/32 DP (only 45 to 100 cm ³ /rev)
C	through drive SAE C 14T, 12/24 DP (only 45 to 100 cm ³ /rev)
CC	through drive SAE C 17T, 12/24 DP (only 85 and 100 cm ³ /rev)

Seals

V	FKM seals
---	-----------

Swash angle sensor

0	no swash angle sensor
S1A	swash angle sensor 4-20 mA with 10-30 VDC
S1B	swash angle sensor 0.5-4.5 V with 10-30 VDC

Pressure sensor

0	no pressure sensor
6A	pressure sensor 4 to 20 mA male connector M12x1
KA	pressure sensor 4 to 20 mA male connector Deutsch
6B	pressure sensor 0 to 10 V male connector M12x1
KB	pressure sensor 0 to 10 V male connector Deutsch

Male connector for solenoids

0	no connector
N	DEUTSCH connector *)

Design number

XX	standard
----	----------

Modification number

YYYY	defined by the manufacturer
------	-----------------------------

Notice:

As standard, the PPV100M is delivered with maximum displacement and without defined pressure setting ($p < 50$ bar). Otherwise please specify in the order accordingly.

*) Alternative male connectors on request

TECHNICAL INFORMATION

2.1 Specifications

Pump size			18	28	45	63	85	100
Geometric displacement	Vg _{max}	[cm ³ /rev]	18.6	28.7	45.7	63.5	85.6	100.7
	Vg _{min} (min. setting)		-	17.8	27.5	44.0	61.3	70.5
Pressure	Nominal pressure	[bar]	315					
	Max. pressure		350					
	Perm. suction pressure		0.8 ~ 5 bar abs.					
	Min. pressure		10					
Maximum pressure change speed		[bar/s]	16000					
Duration of action, max. pressure	Total	[h]	300					
	Single	[ms]	5					
Drive speed	Min.	[rpm]	600					
	Max. at Vg _{min}		3600	3600	3300	2700	2700	2600
	Max. at Vg _{max}		3400	3200	2700	2600	2500	2300
Power (at 1500 rpm, 315 bar) *)		[kW]	14.6	22.6	36	50	67.4	79.3
Pre-fill oil volume		[cm ³]	450	470	790	900	1300	
Approx. weight (with pressure control P)		[kg]	12.7	14.7	21	25	37.7	
Moment of inertia		[kgm ²]	0.00093	0.0015	0.0034	0.0053	0.011	
Max. permitted axial shaft load		[N]	700	1000	1500	2000	3000	
Max. permitted radial shaft load			350	1200	1500	1700	2000	

*) without efficiency

2.2 Max. permissible drive and through drive torques

Pump size			18	28	45	63	
Mounting flange			SAE A, 2-hole	SAE B, 2-hole	SAE B, 2-hole	SAE B, 2-hole	SAE C, 4-hole
Max. perm. drive torque	S-shaft (standard)	[Nm]	11T-16/32DP	13T-16/32DP	15T-16/32DP		14T-12/24DP
		[Nm]	157	261	402		720
	S1-shaft	[Nm]	-	-	13T-16/32DP	-	
		[Nm]	-	-	261 *)	-	
T-shaft	[Nm]	11T-16/32DP	13T-16/32DP	15T-16/32DP		14T-12/24DP	
	[Nm]	172	298	474		893	
T1-shaft	[Nm]	-	-	13T-16/32DP	-		
	[Nm]	-	-	298	-		
Max. perm. through drive torque	SAE A		160				
	SAE AB		172				
	SAE B		172		298		
	SAE BB		-	-	404	472	
	SAE C		-	-	472		
	SAE CC		-	-	-	-	-

Pump size			85		100	
Mounting flange			SAE C, 2-hole	SAE C, 4-hole	SAE C, 2-hole	SAE C, 4-hole
Max. perm. drive torque	S-shaft (standard)	[Nm]	17T-12/24DP			
		[Nm]	1354			
	S1-shaft	[Nm]	14T-12/24DP			
		[Nm]	720			
T-shaft	[Nm]	-				
	[Nm]	-				
T1-shaft	[Nm]	14T-12/24DP				
	[Nm]	893				
Max. perm. through drive torque	SAE A		160			
	SAE AB		172			
	SAE B		298			
	SAE BB		474			
	SAE C		848			
	SAE CC		848			

*) Max. permissible pressure p = 315 bar or alternatively reduction of displacement to 0.9 x Vg_{max}

2.3 Pump combinations PPV100M and through drives

Secondary stage \ Primary stage	18	28	45	63	85	100
18	•					
28	•	•				
45	•	•	•			
63	•	•	•	•		
85	•	•	•	•	•	
100	•	•	•	•	•	•

Through drive	18	28	45	63	85	100
SAE A	•	•	•	•	•	•
SAE AB	•	•	•	•	•	•
SAE AI			•	•		
SAE B	•	•	•	•	•	•
SAE BB			•	•	•	•
SAE C			•	•	•	•
SAE CC					•	•

2.4 Seals

The pump series is equipped with fluorocarbon (FKM) seals as standard.

If special fluids are used, it may be necessary to use seals made from a different material.

2.5 Filtration

For a maximum service life of the pump and system components, the system must be protected from contamination by effective filtration.

The cleanliness class to NAS 1638 Class 9 (20/18/14 ISO 4406:1999) or cleaner.

2.6 Operating fluids

The pump series is designed for use with

HLP hydraulic oils to DIN 51524 Part 2

Before using alternative fluids, please contact HYDAC Drive Center:

HEES environmentally friendly pressure fluid based on synthetic ester

HFD-U fire-resistant pressure fluid based on polyolester

HFD-R fire-resistant pressure fluid based on phosphate ester

HEPR environmentally friendly hydraulic fluid based on poly-alpha-olefins

2.7 Temperature and viscosity range

	Viscosity [cSt (mm ² /s)]	Temperature [°C]	Comment
Cold start	≤ 1600	≥ -40	t ≤ 1 min, p ≤ 30 bar, n ≤ 1000 rpm, measured at suction port
Continuous operation	15 - 400	≥ -25	Measured at suction port
		≤ +115	Measured at drain port
Optimal	20 - 60		
Short-time duty	≥ 7		t ≤ 1 min, p ≤ 80 bar

For low temperature applications, please contact HYDAC Drive Center.

2.8 Adjustment notes

As standard, the PPV00M is delivered with maximum displacement and without defined pressure setting ($p < 50$ bar). Pressure and displacement can be adjusted using adjustment screws to meet your system requirements.

Pump size	Displacement		Pressure adjustment screw rate [bar/rev]
	Displacement adjustment screw rate [cm ³ /rev]	Min. displacement setting [cm ³ /rev]	
PPV100M18	-	-	40
PPV100M28	3.7	17.8	
PPV100M45	5.6	27.5	
PPV100M63	7.3	44.0	
PPV100M85	9.9	61.3	
PPV100M100	9.9	70.5	

Please note:

The pump pressure control is not a substitute for the hydraulic system's pressure safety. A separate pressure limiting valve must be provided to secure the hydraulic system against overpressure.

2.9 Installation notes

The pump shall be installed with the case drain line initially rising vertically above the level of the pump before continuing to the tank as shown in the Figure on the next page. Do not connect the drain line to the suction line.

The top drain port must always be used. The internal diameter of the drain line must be equal to or greater than the drain port to keep the pressure in the pump case as low as possible. The pressure in the pump case must not exceed 1 bar as shown in the Figure below. Peak pressure must never exceed 4 bar.

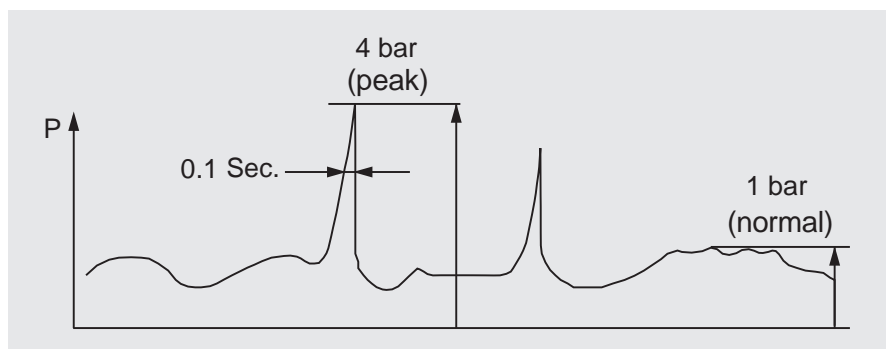

Installing the pump above the tank

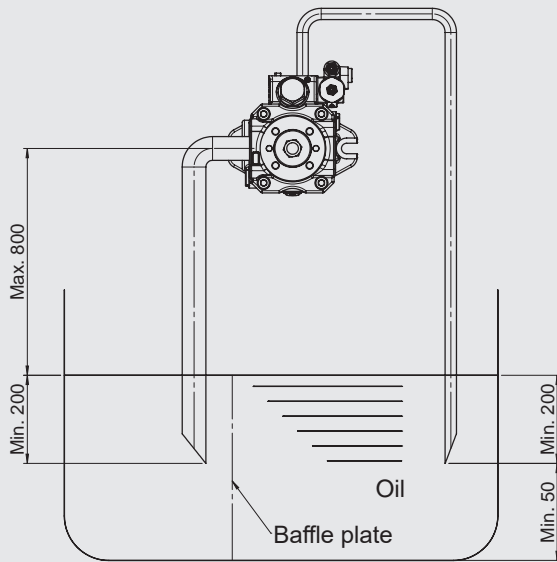

Precautions:

Before commissioning, fill the pump with oil and vent the pipes.

The suction and drain lines must be immersed at least 200 mm below the lowest oil level under operating conditions.

The height between the suction line and the oil level is determined by the total pressure loss, but must not exceed 800 mm.

The minimum intake pressure at port S must not drop below 0.8 bar (absolute) during operation, with ambient pressure = 1 bar (absolute).

If the pump is installed in a different way, please contact HYDAC Drive Center.

Installing the pump inside the tank

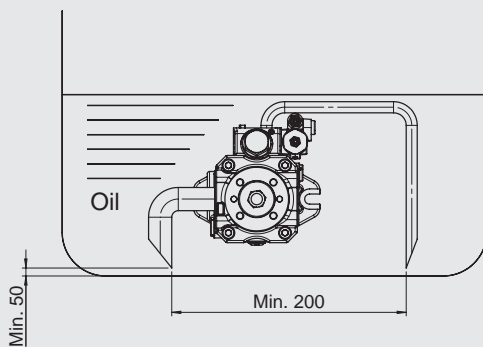

Installing the pump beneath the tank

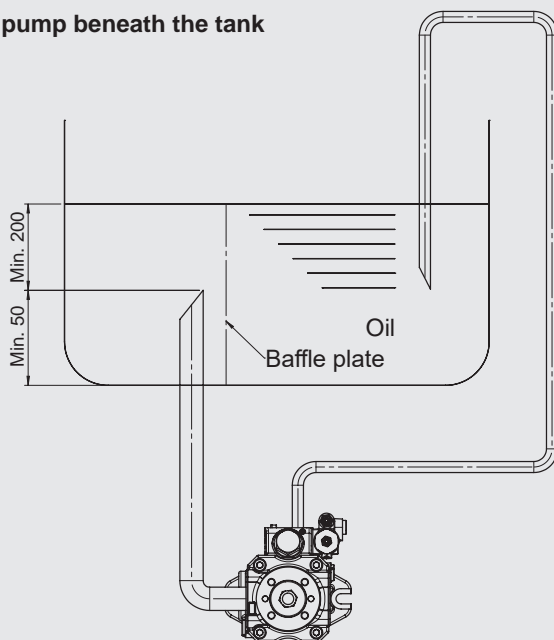

CONTROL OPTIONS

3.1 Pressure control P

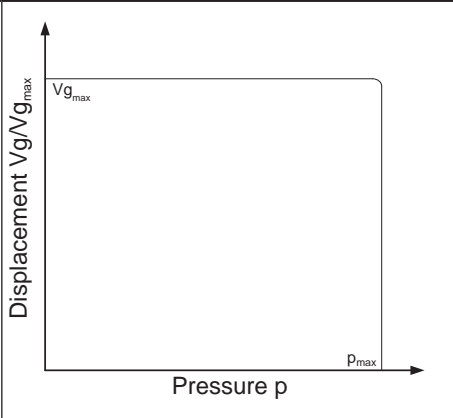
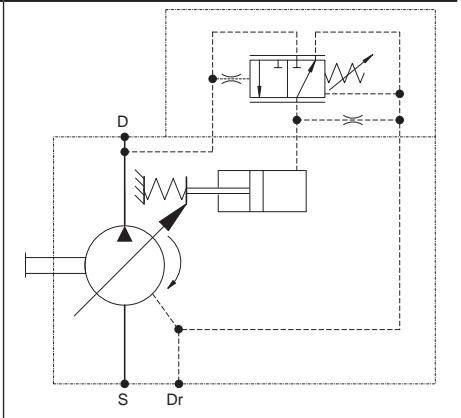
Description	Performance characteristics	Hydraulic diagram
<p>When the system pressure reaches the set pressure value, the displacement of the pump decreases and keeps it constant (pressure cut-off).</p> <p>Min. pressure setting: 25 bar</p> <p>Pressure control: no defined setting ($p < 50$ bar)</p>		

3.2 Pressure remote control PR

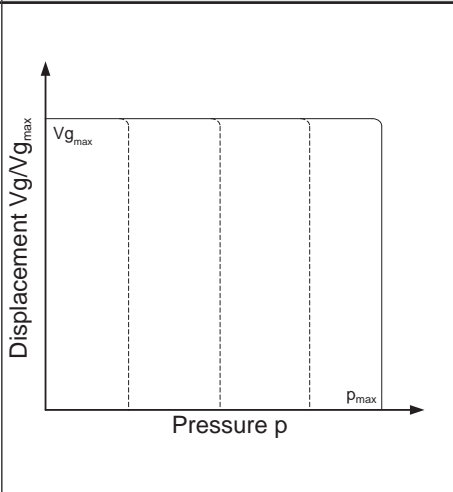
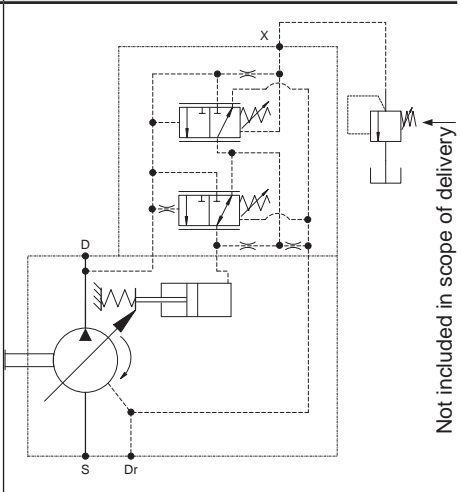
Description	Performance characteristics	Hydraulic diagram
<p>When the system pressure reaches the set pressure value, the displacement of the pump decreases and keeps it constant (pressure cut-off).</p> <p>The pressure cut-off can occur directly via the PR control. Alternatively, this function is also possible by means of an external pressure limiting valve at port X (pressure remote control).</p> <p>Standard setting of the pressure control: Differential pressure compensator: 15 bar</p> <p>Main control pressure stage: no defined setting ($p < 50$ bar)</p> <p>Min. pressure setting: 25 bar</p>		 <p style="text-align: right;">Not included in scope of delivery</p>

3.3 Load-sensing control LS / LS0

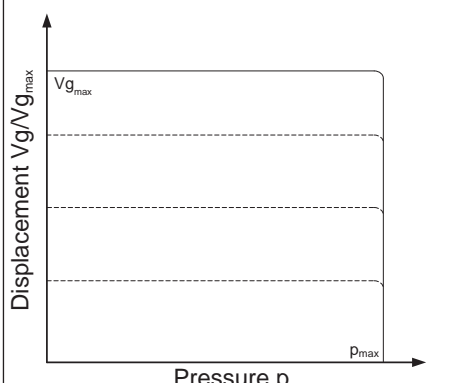
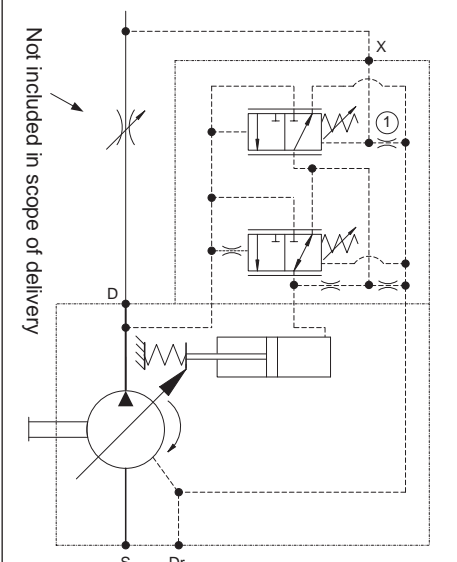
Description	Performance characteristics	Hydraulic diagram
<p>The LS pressure compensator is used to control the displacement of the pump in such a way that the pressure drop at the throttle in the pressure line remains constant irrespective of the load. When the system pressure reaches the set pressure value, the displacement of the pump decreases and keeps it constant.</p> <p>In the LS version, there is no internal connection from port X to drain. The LS pressure release must take place outside the pump in the hydraulic system.</p> <p>Standard setting of the load-sensing control:</p> <p>LS pressure compensator: 15 bar</p> <p>Main control pressure stage: no defined setting ($p < 50$ bar)</p> <p>Min. pressure setting: 25 bar</p> <p>Potential setting range of the LS pressure compensator: 10 - 30 bar</p>		

① LS0: with orifice; LS: with plug

3.4 Electrical displacement control ED

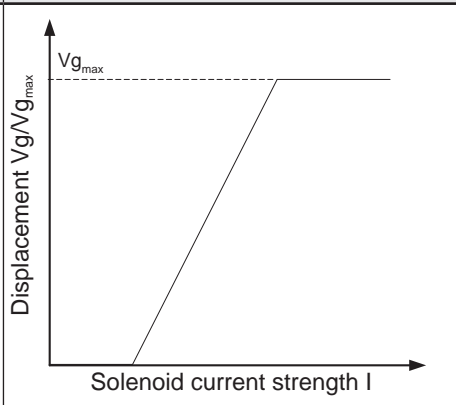
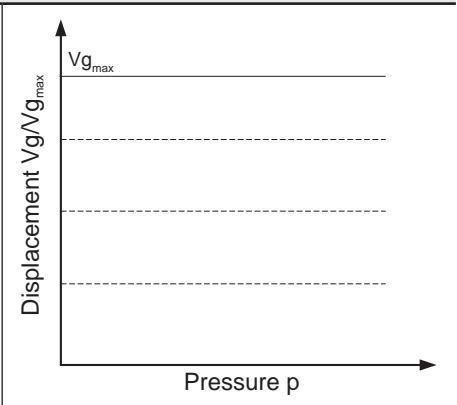
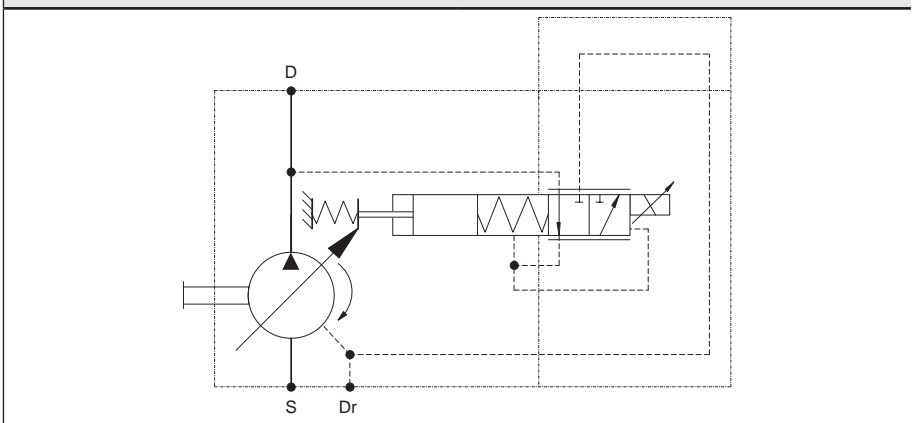
Description	Performance characteristics	
<p>The displacement of the pump is set by an electrical signal at the solenoid coil of the ED control.</p> <p>Specific characteristics of the ED control, please see sec. 3.8</p>		
Hydraulic diagram		
		

3.5 Electrical displacement control and pressure control EDP

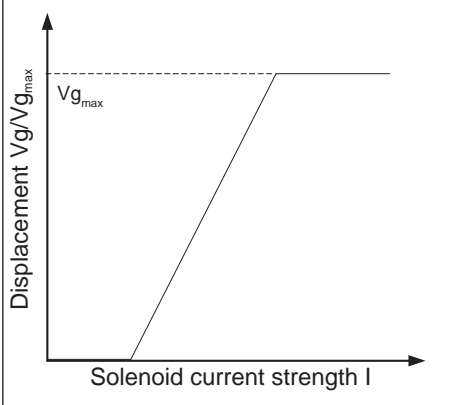
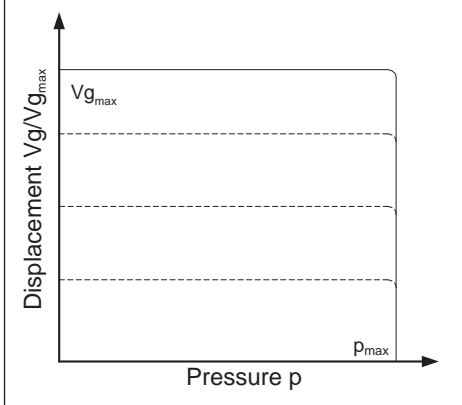
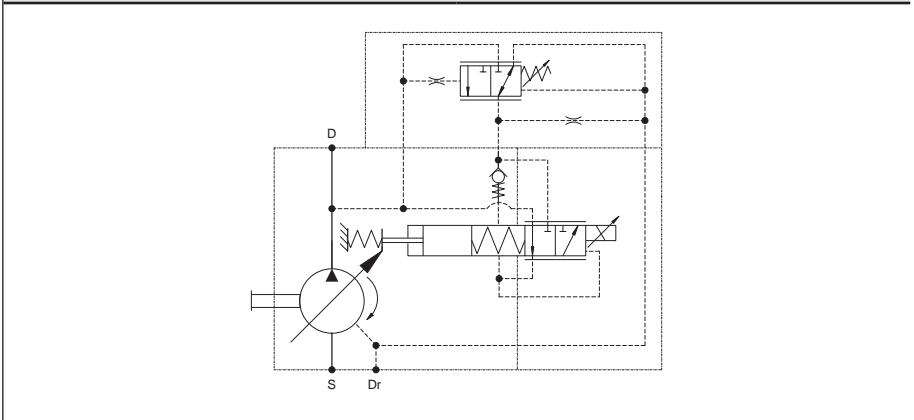
Description	Performance characteristics	
<p>The displacement of the pump is set by an electrical signal at the solenoid coil of the EDP control. When the system pressure reaches the set pressure value, the displacement of the pump decreases and keeps it constant.</p> <p>Specific characteristics of the EDP control, please see sec. 3.8</p> <p>Min. pressure setting: 25 bar</p> <p>Pressure control: no defined setting ($p < 50$ bar)</p>		
Hydraulic diagram		
		

3.6 Electrical displacement control and pressure remote control EDPR

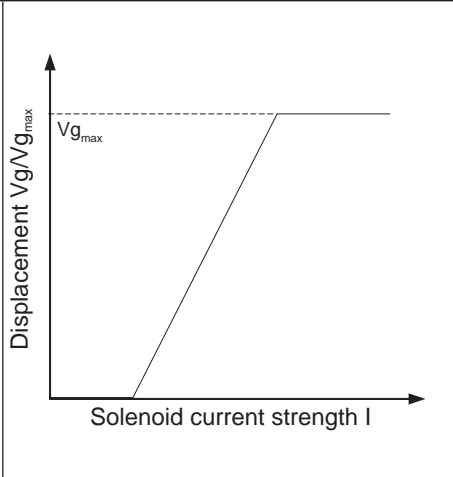
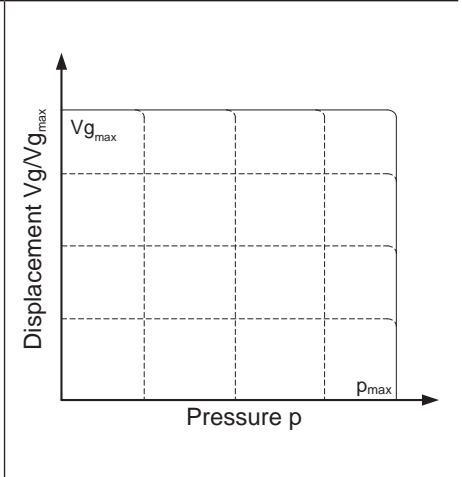
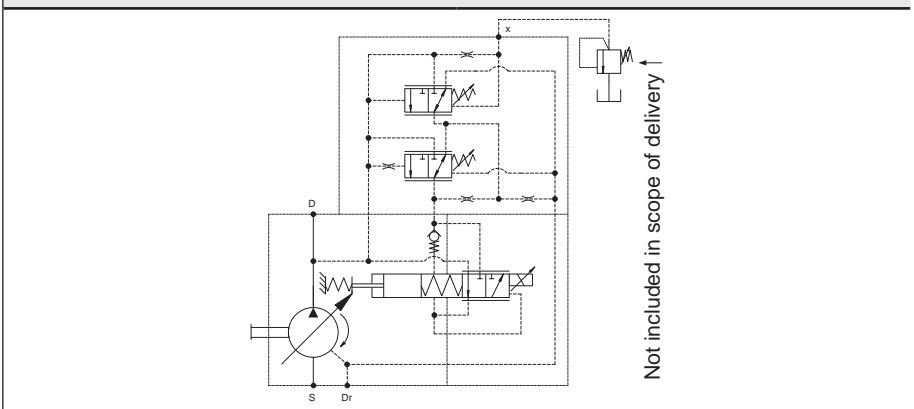
Description	Performance characteristics	
<p>The displacement of the pump is set by an electrical signal at the solenoid coil of the EDPR control. When the system pressure reaches the set value, the displacement of the pump decreases and remains constant (pressure cut-off).</p> <p>The pressure setting can occur directly via the EDPR control. Alternatively, this function is also possible by means of an external pressure limiting valve at port X (pressure remote control).</p> <p>Specific characteristics of the EDPR control, please see sec. 3.8</p> <p>Standard setting of the EDPR control:</p> <p>Differential pressure compensator: 15 bar</p> <p>Main control pressure stage: no defined setting ($p < 50$ bar)</p> <p>Min. pressure setting: 25 bar</p>		
Hydraulic diagram		
 <p style="text-align: right;">Not included in scope of delivery ↑</p>		

3.7 Electrical displacement control and load-sensing control EDLS / EDLS0

Description	Performance characteristics	
<p>The displacement of the pump is set by an electrical signal at the solenoid coil of the ED control.</p> <p>The LS pressure compensator of the EDLS/EDLS0 control keeps the pressure loss at the throttle constant regardless of the load.</p> <p>The load-sensing control superimposes the pump displacement set at the solenoid of the EDLS/EDLS0 controller.</p> <p>When the system pressure reaches the set value, the displacement of the pump decreases and remains constant (pressure cut-off).</p> <p>In the EDLS version, there is no internal connection from port X to drain. The LS pressure release must take place outside the pump in the hydraulic system.</p> <p>Specific characteristics of the EDLS/EDLS0 control, please see sec. 3.8</p> <p>Standard setting of the EDLS/EDLS0 control:</p> <p>LS pressure compensator: 15 bar</p> <p>Main control pressure stage: no defined setting ($p < 50$ bar)</p> <p>Min. pressure setting: 25 bar</p> <p>Potential setting range of the LS pressure compensator: 10 - 30 bar</p>		
Hydraulic diagram		

① LS0: with orifice; LS: with plug

3.8 Specific characteristics of the ED / EDP / EDPR / EDLS / EDLS0 control

Description		Performance characteristics
Operation voltage:	Either 12V or 24V	
Max. perm. current:	12 V coil: 1.75 A 24 V coil: 0.85 A	
Resistance at 20 °C:	12 V coil: 4.1 ohms 24 V coil: 17.6 ohms	
Thermal class (to VDE 0580):	H	
Control range:	500 to 1300 mA for 12V version 250 to 650 mA for 24V version	
Duty cycle:	100 % for the specified control range	
Dither frequency on control current:	150 Hz (recommended, may differ for specific application)	
Minimum pressure for secure control function:	20 bar	
IP protection type (to EN60529):	Deutsch connector IP69 DIN connector IP65 Other connector types on request	
Permitted ambient temperature:	-20 °C to + 85 °C (observe max. permissible operating temperature of the pump)	

PERFORMANCE DATA

4.1 PPV100M18

Drive power at $V_{g_{max}}$

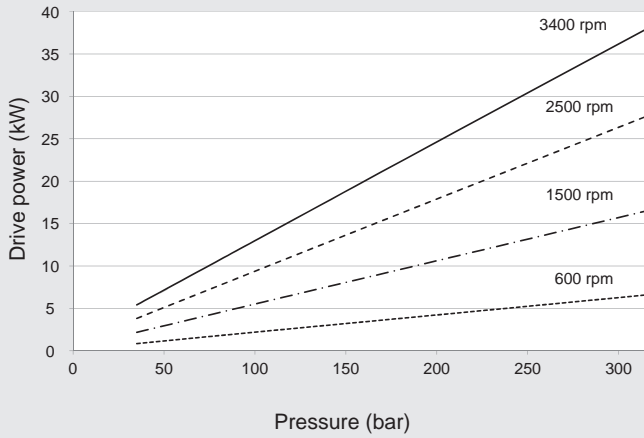

Flow rate Q_{max}

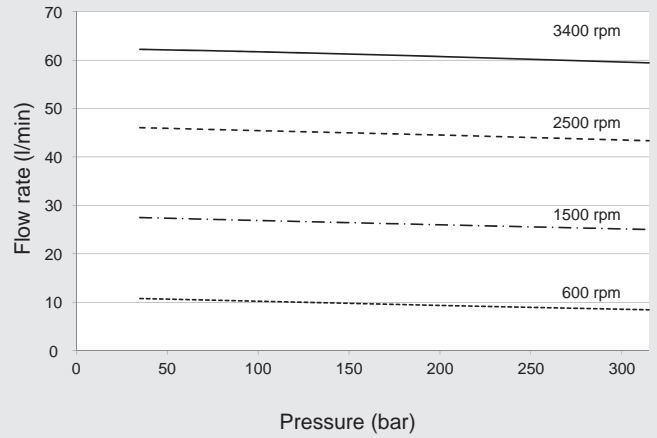

Drive power at pressure cut-off

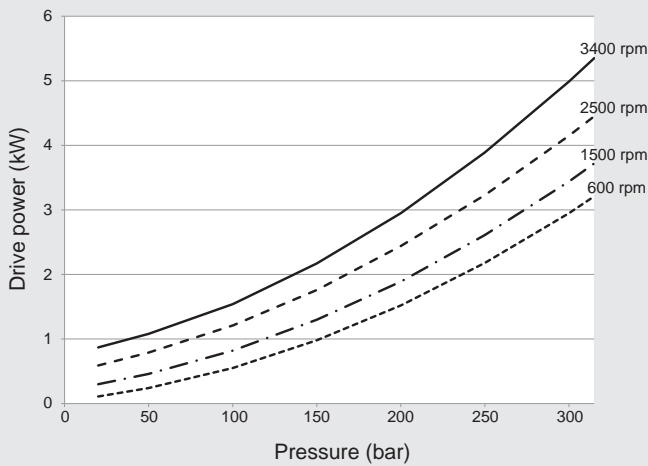

Self-priming capability

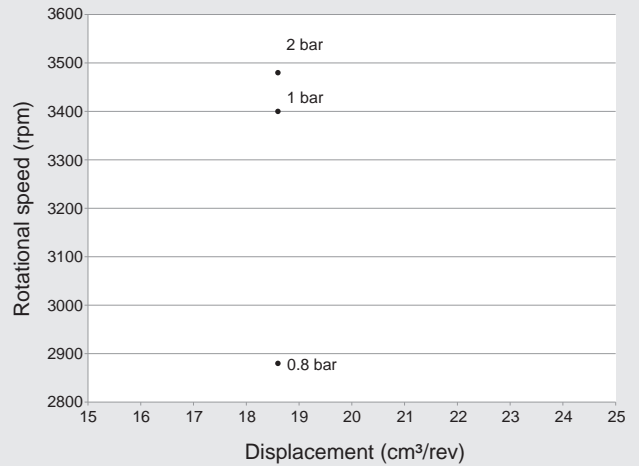

Drive power at $V_{g_{max}}$

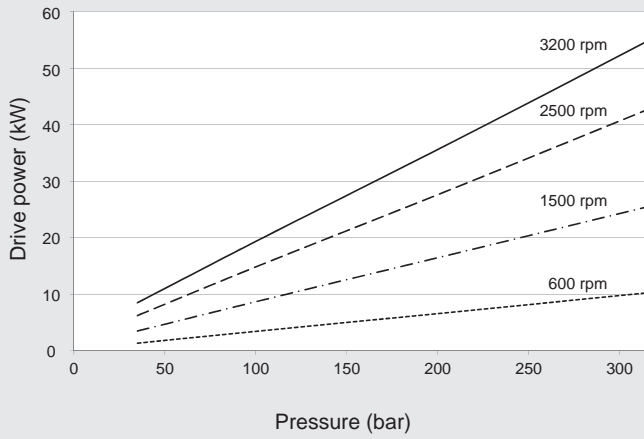

Flow rate Q_{max}

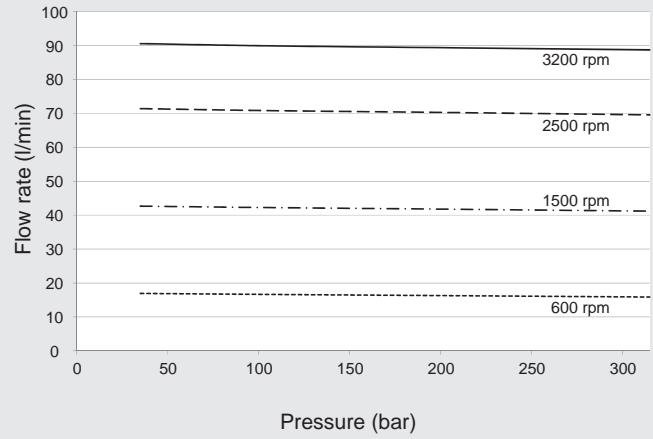

Drive power at pressure cut-off

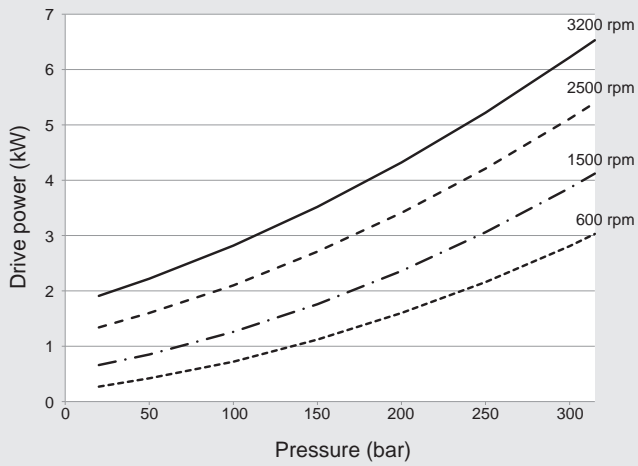

Self-priming capability

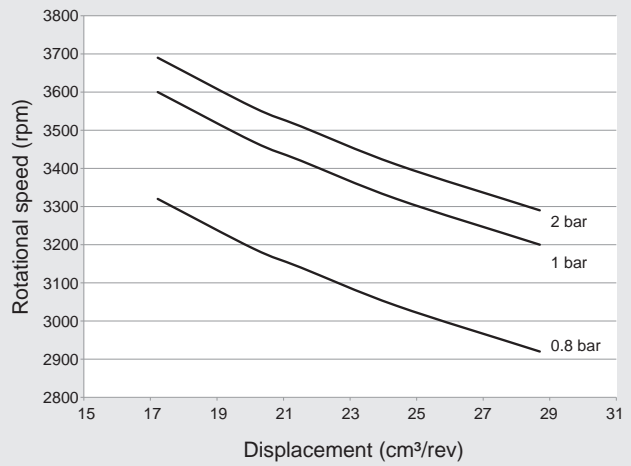

Drive power at $V_{g_{max}}$

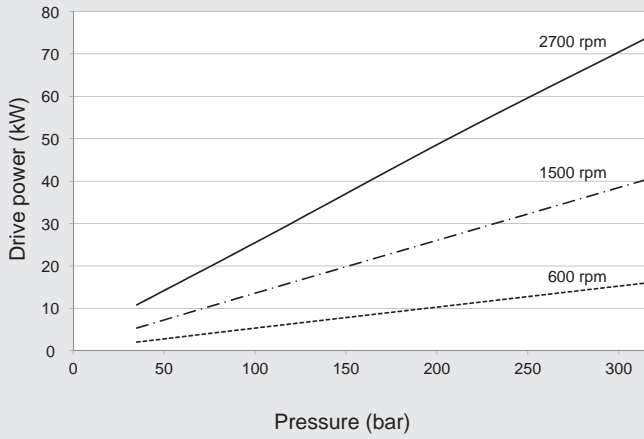

Flow rate Q_{max}

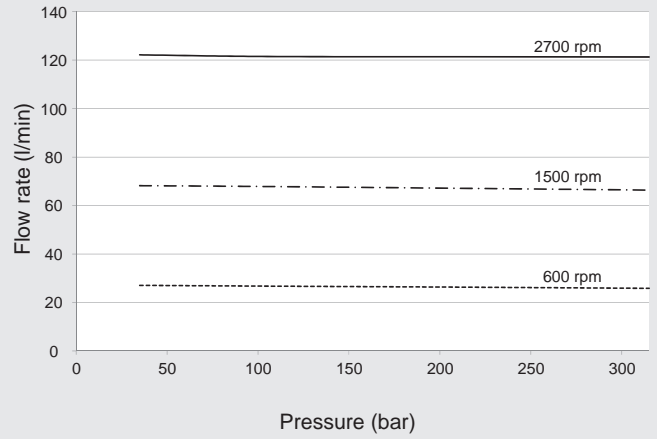

Drive power at pressure cut-off

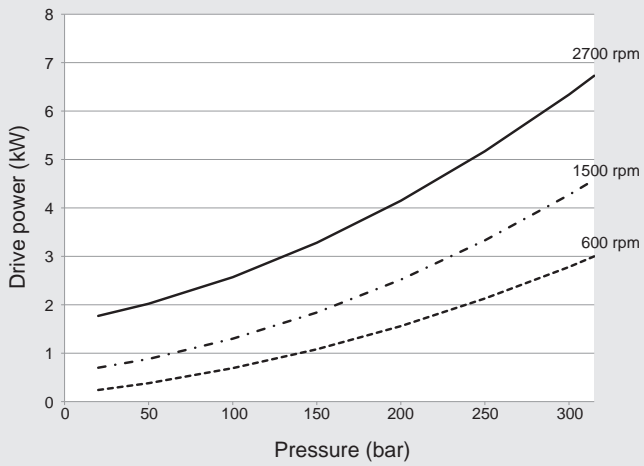

Self-priming capability

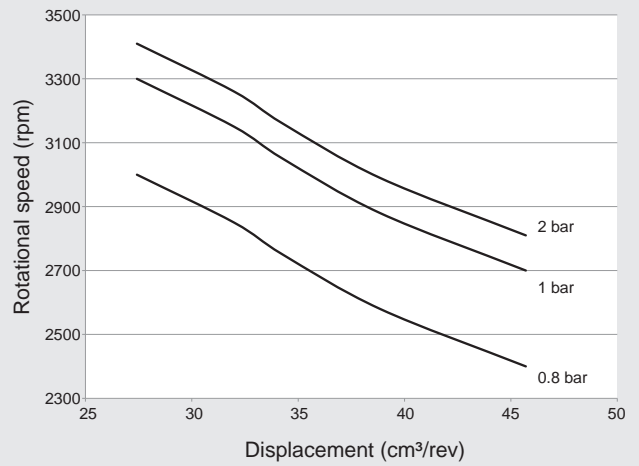

Drive power at $V_{g_{max}}$

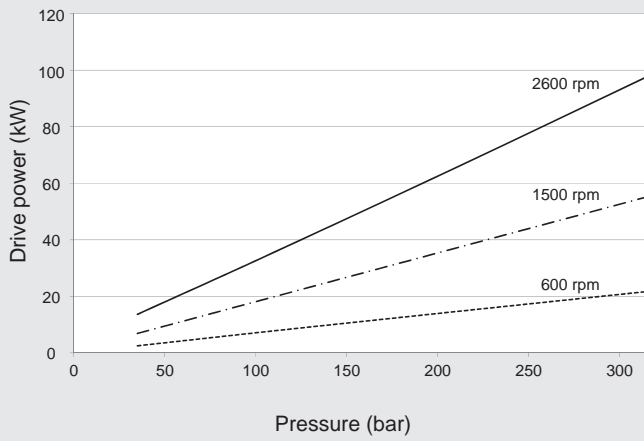

Flow rate Q_{max}

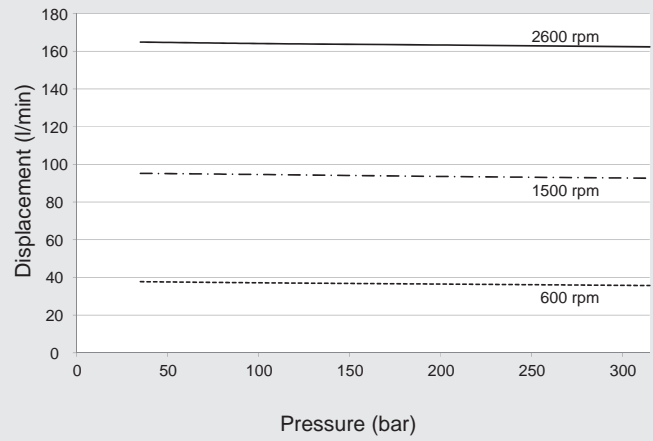

Drive power at pressure cut-off

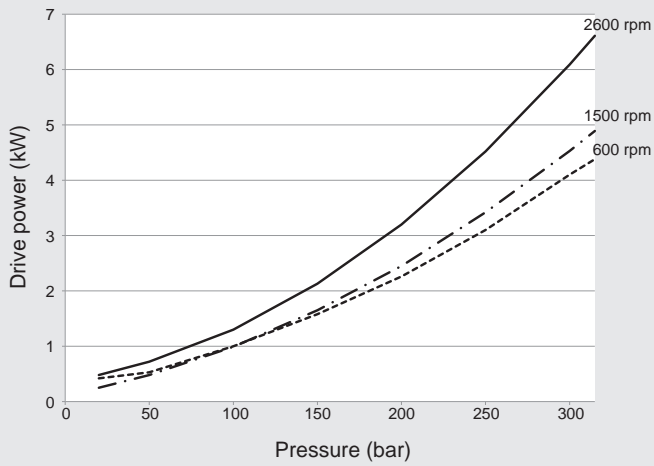

Self-priming capability

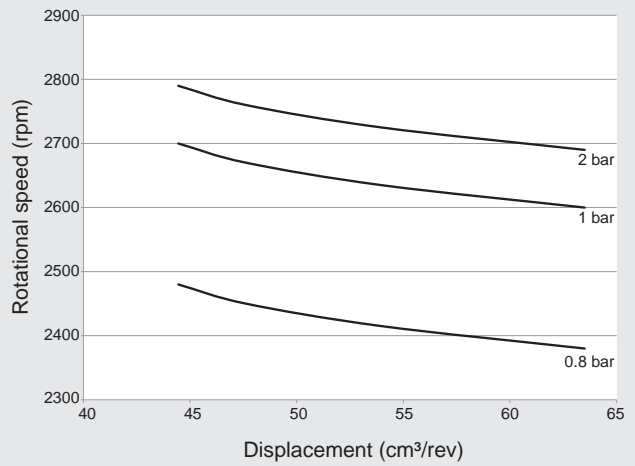

Drive power at $V_{g_{max}}$

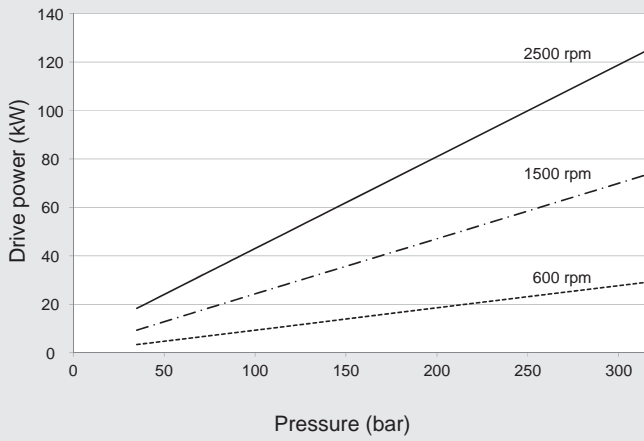

Flow rate Q_{max}

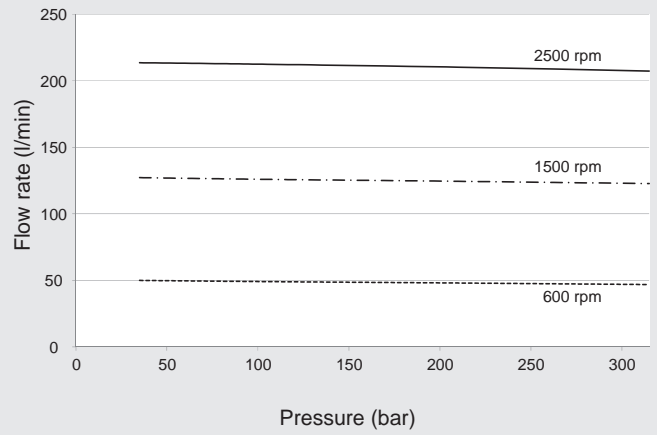

Drive power at pressure cut-off

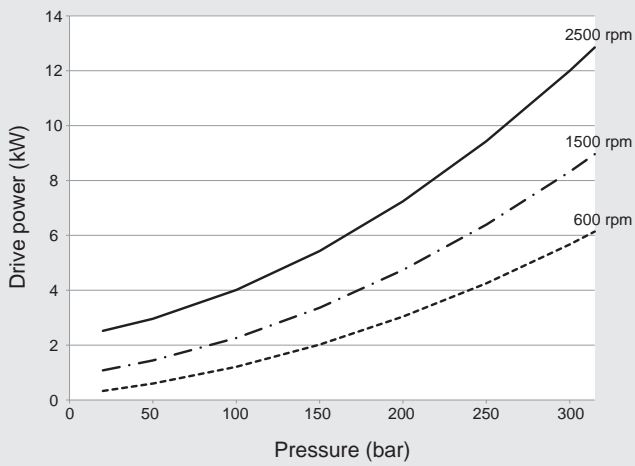

Self-priming capability

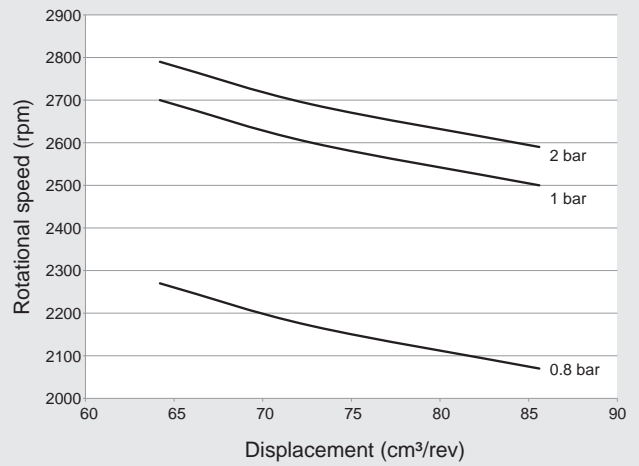

Drive power at $V_{g_{max}}$

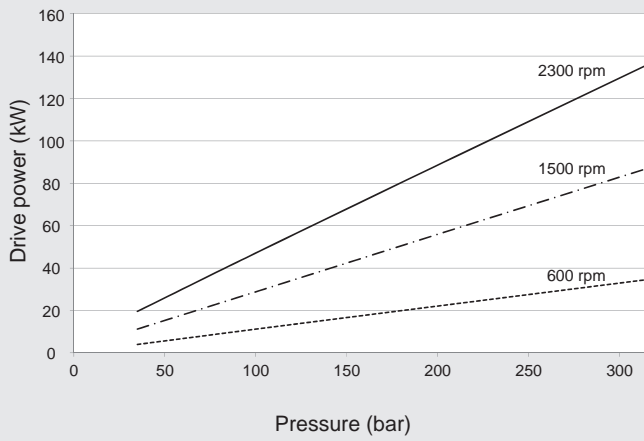

Flow rate Q_{max}

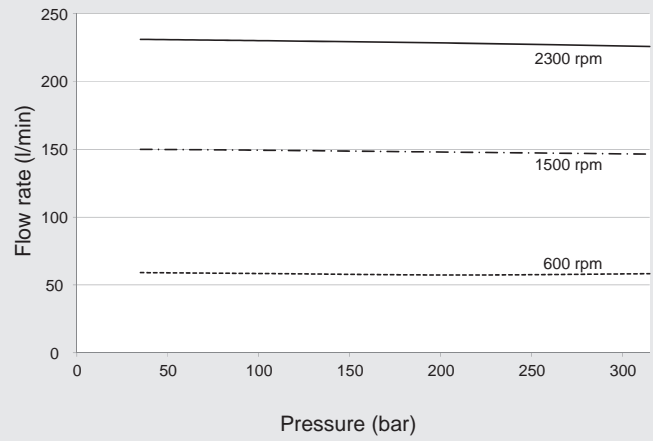

Drive power at pressure cut-off

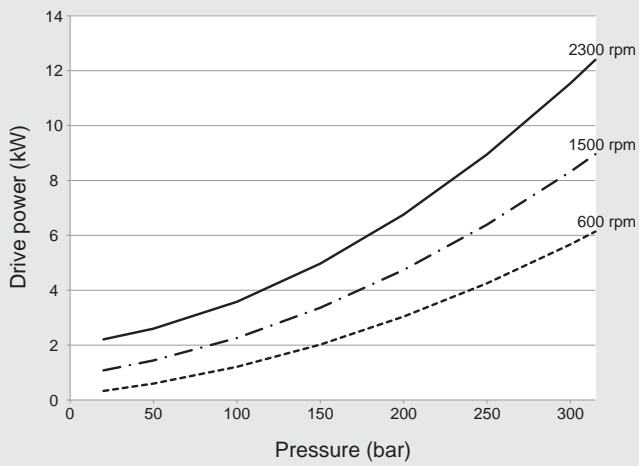

Self-priming capability

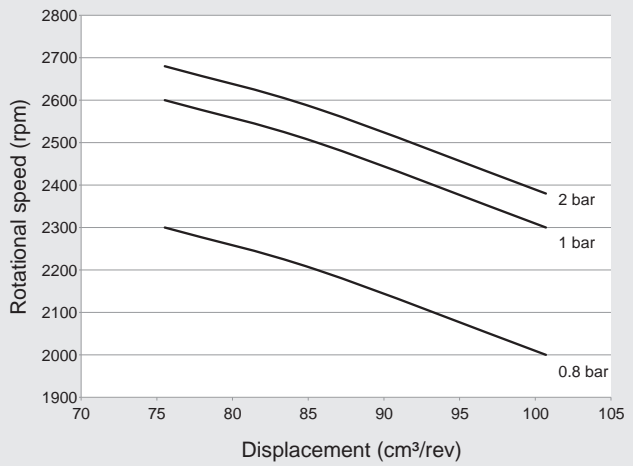

DIMENSIONS

5.1 PPV100M18

PPV100M18 clockwise rotation with pressure control P

(Notice: for anti-clockwise rotation, suction port and pressure port are reversed)

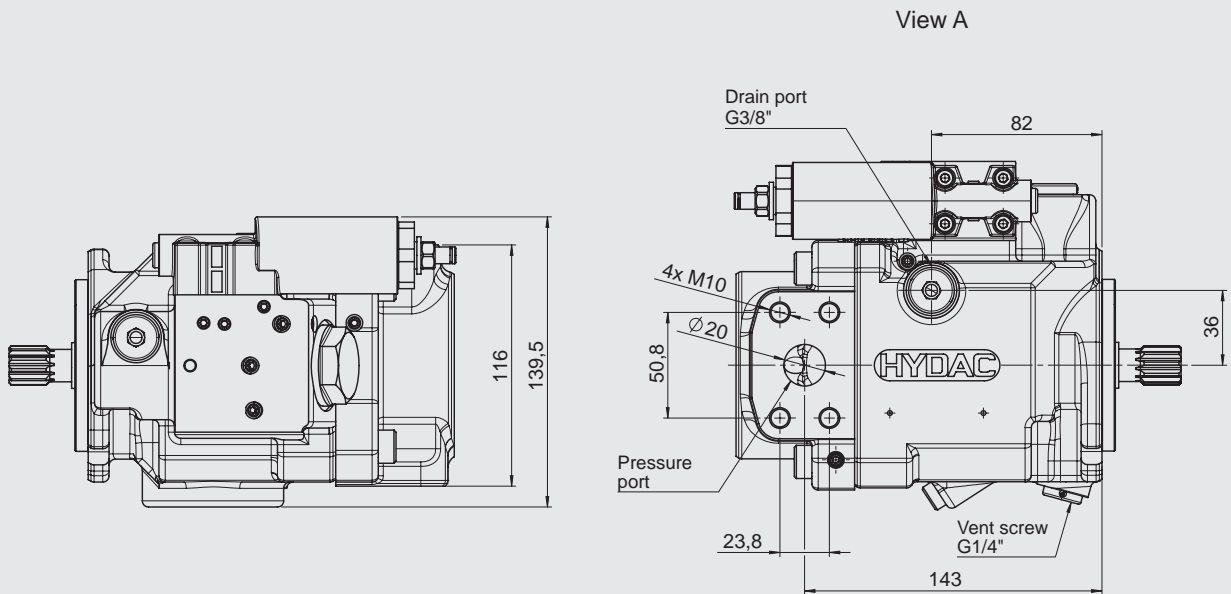
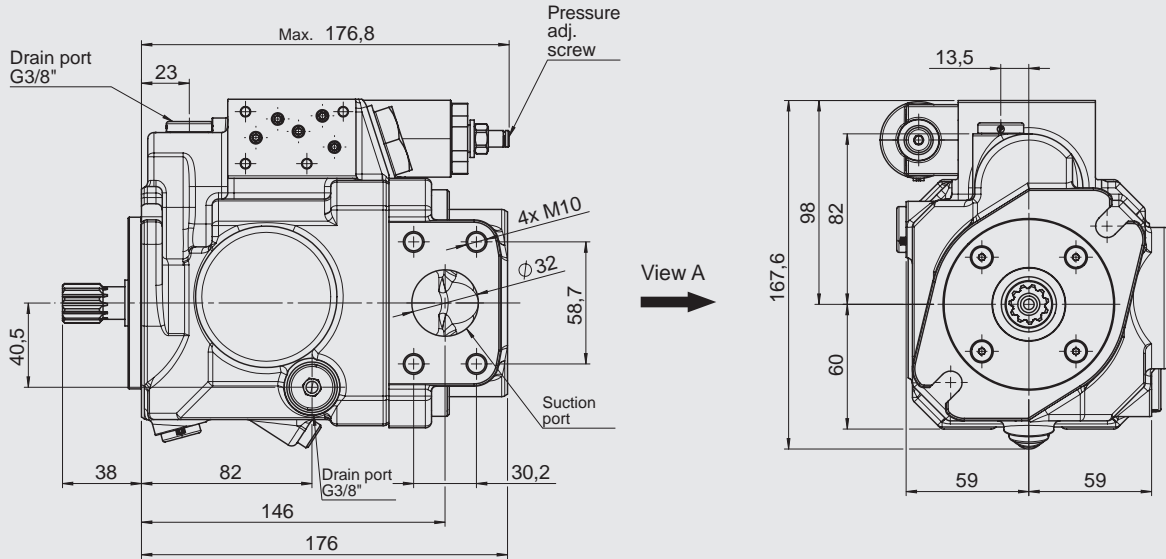

Mounting flange and shaft options

"A2" SAE A, 2-hole flange

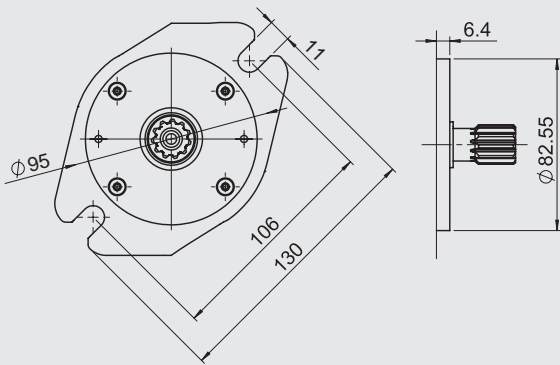

"S" SAE AB splined shaft

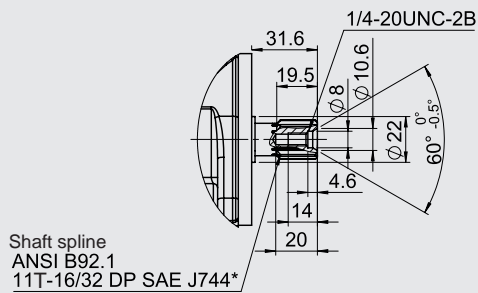

*30° pressure angle, flat root, side fit

"T" SAE AB splined shaft

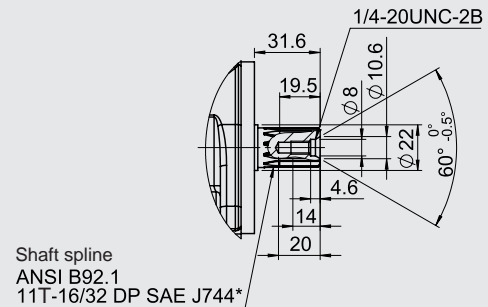

*30° pressure angle, flat root, side fit

PPV100M18 with load-sensing control LS / LS0 / pressure remote control PR

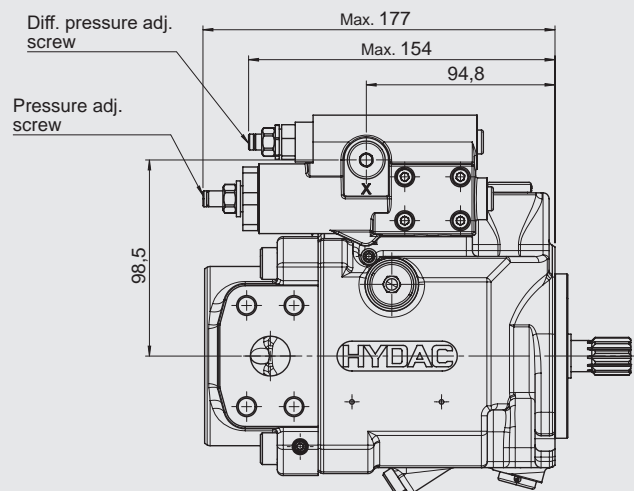
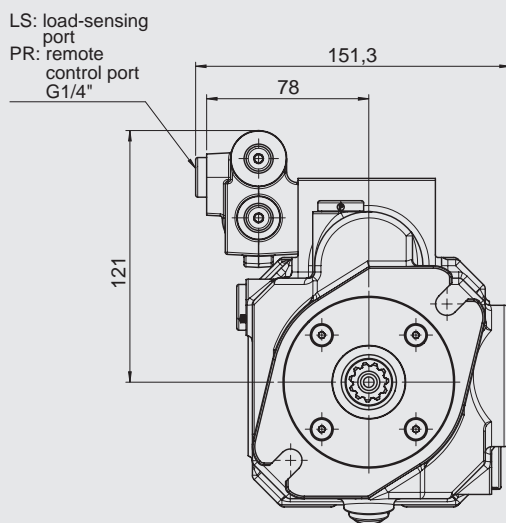

PPV100M18 with electrical displacement control ED

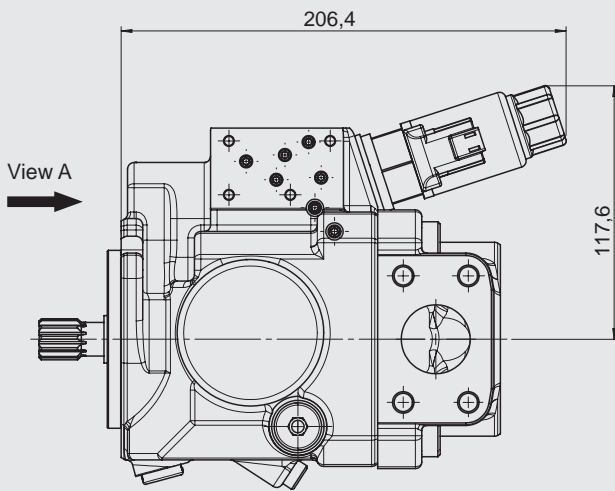

View A

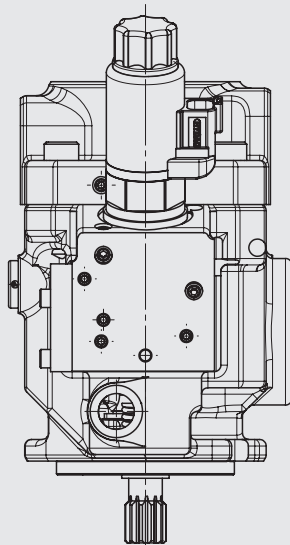
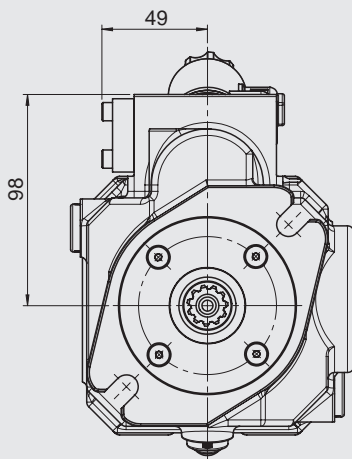

PPV100M18 with electrical displacement control and pressure control EDP

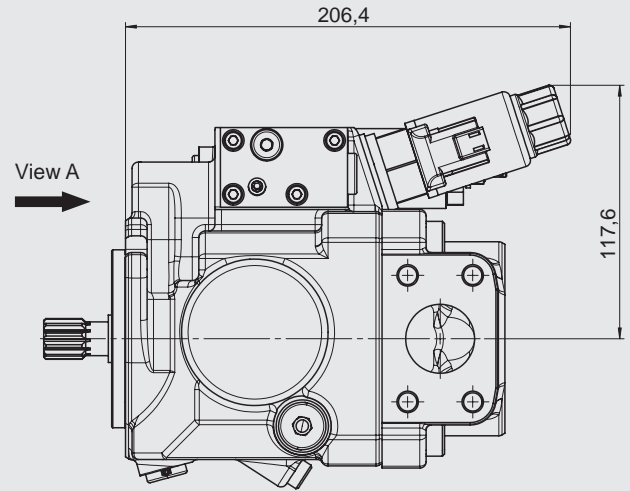

View A

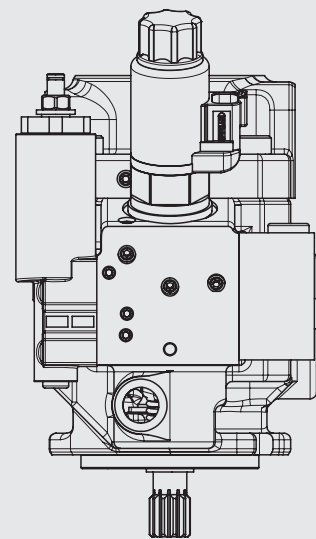
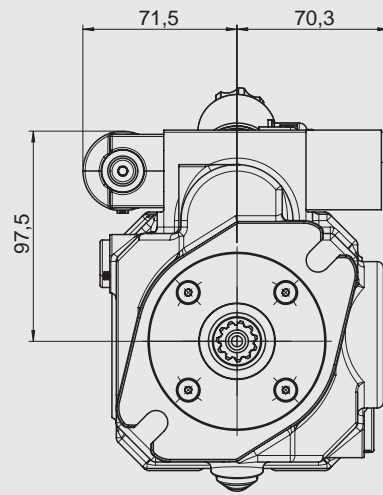

PPV100M18 with electrical displacement control and load-sensing control EDLS / EDLS0 / pressure remote control EDPR

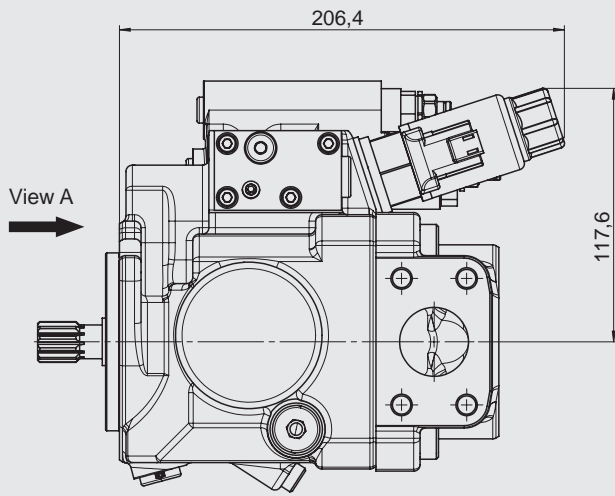

View A

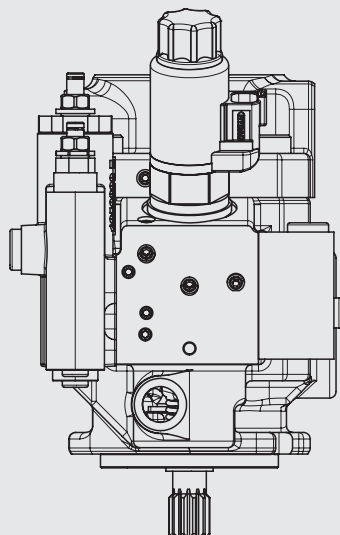
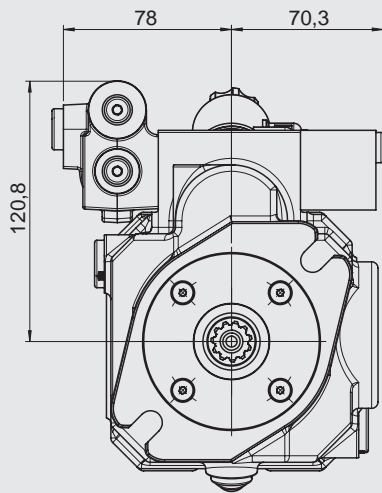

Dimensions PPV100M18 with swash angle sensor on request

PPV100M18 through drive options

Through drive SAE A

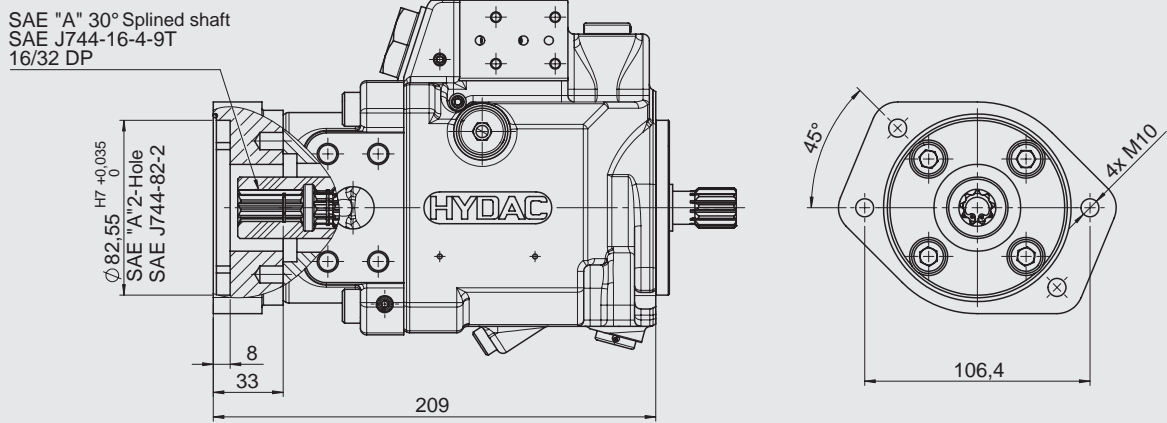

Through drive SAE AB

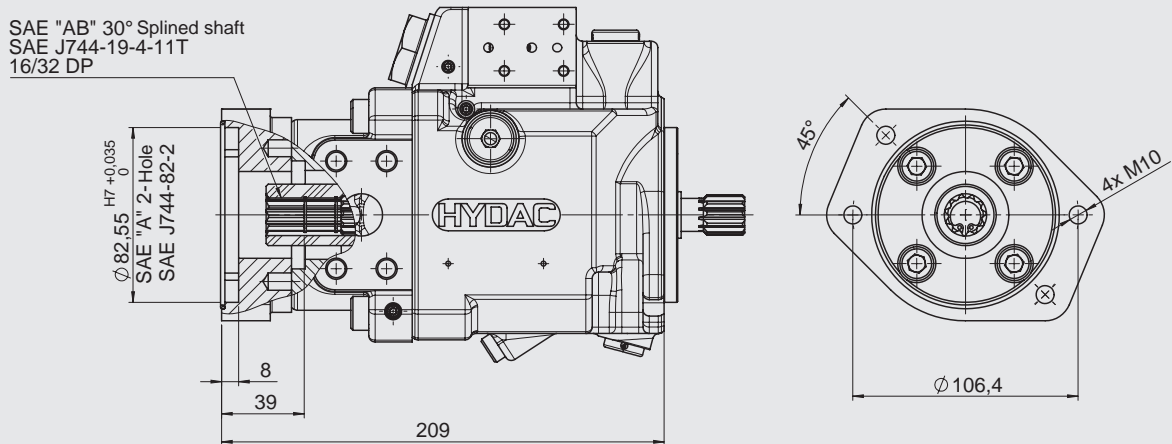

Through drive SAE B

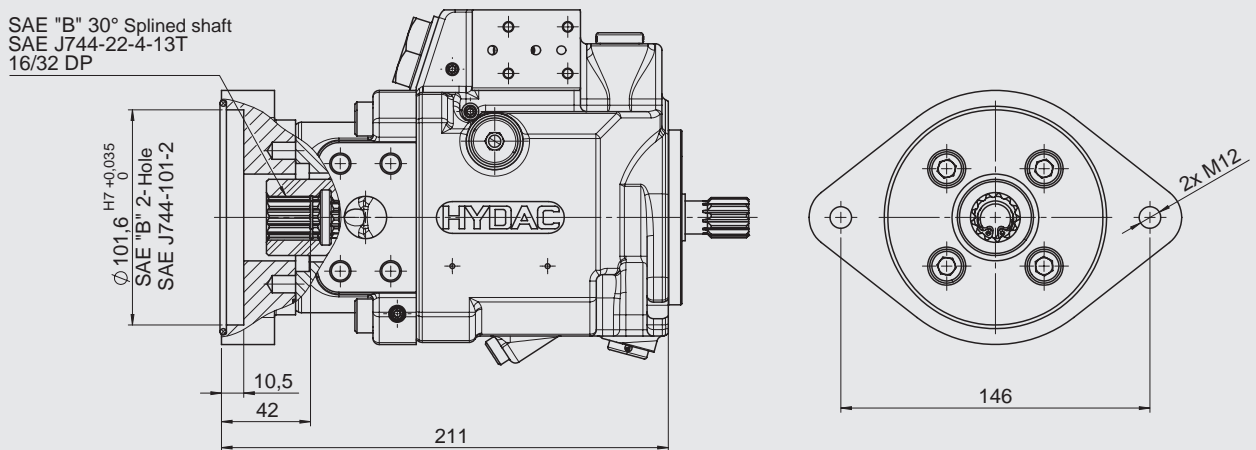

PPV100M28 clockwise rotation with pressure control P

(Notice: for anti-clockwise rotation, suction port and pressure port are reversed)

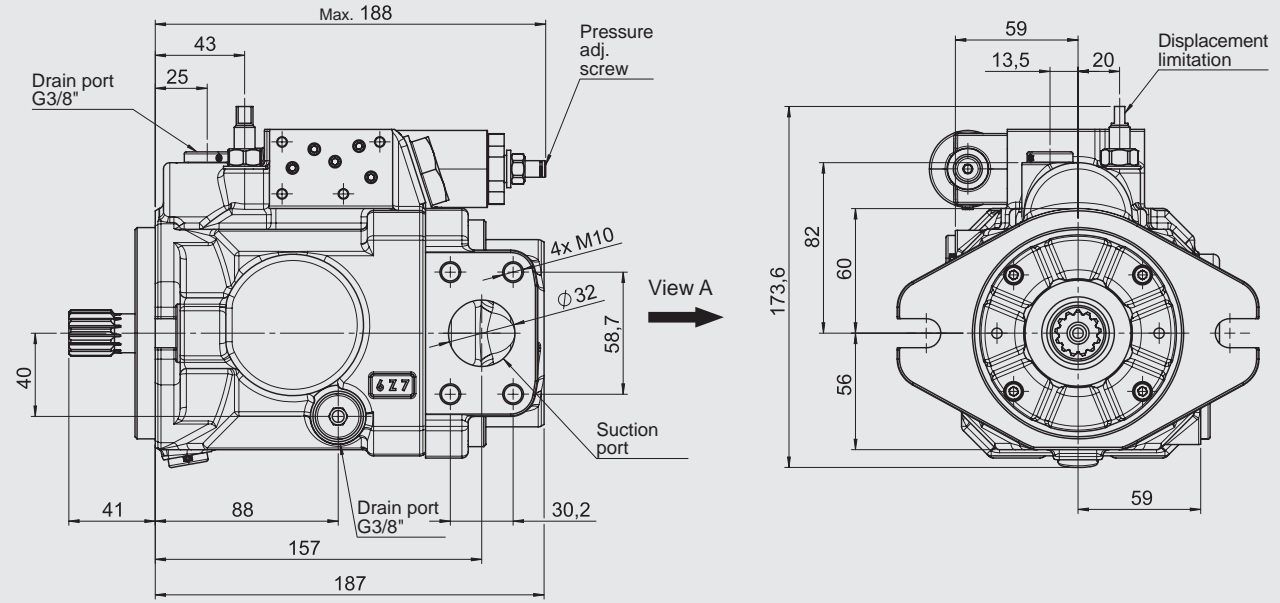

View A

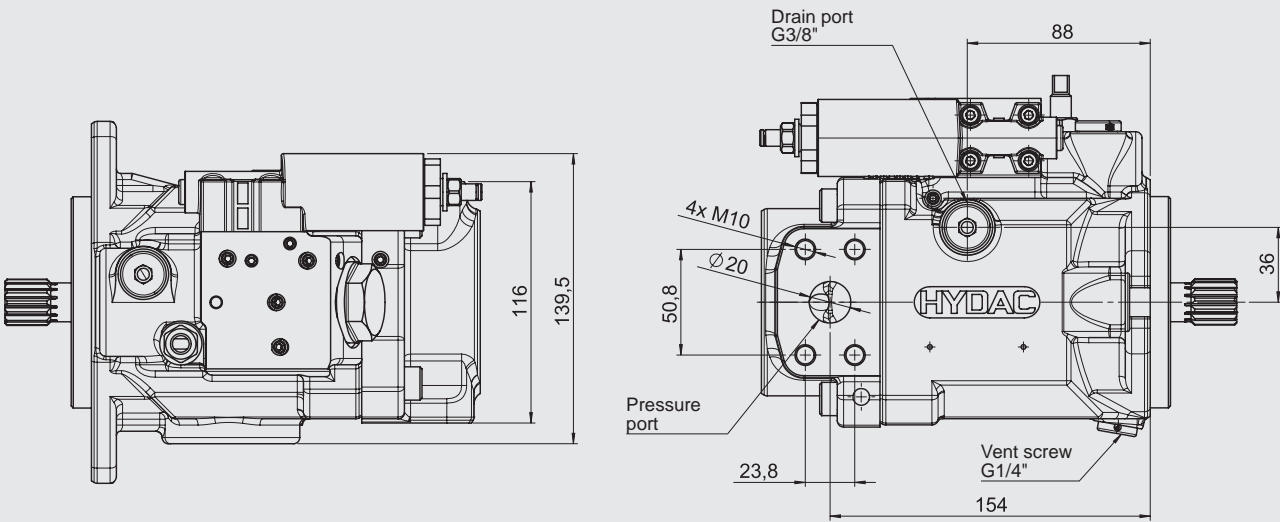

Mounting flange and shaft options

"B2" SAE B – 2-hole flange

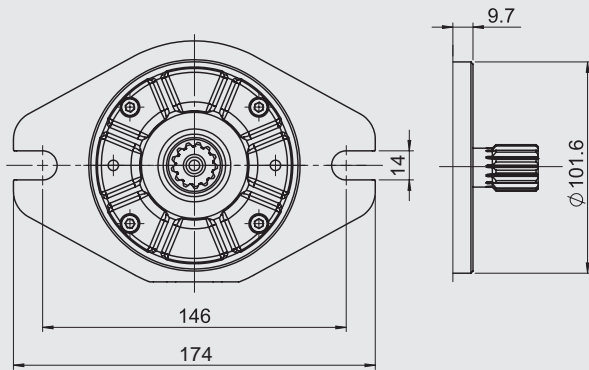

"S" SAE B splined shaft

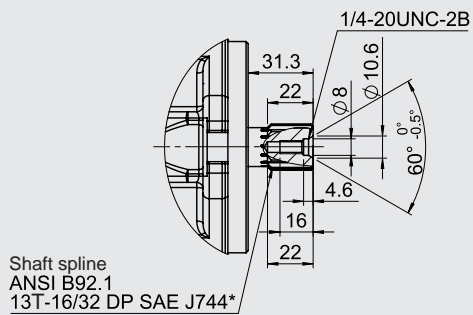

"T" SAE B splined shaft

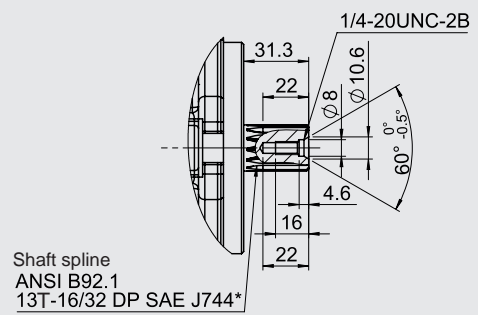

*30° pressure angle, flat root, side fit

*30° pressure angle, flat root, side fit

PPV100M28 with load-sensing control LS / LS0 / pressure remote control PR

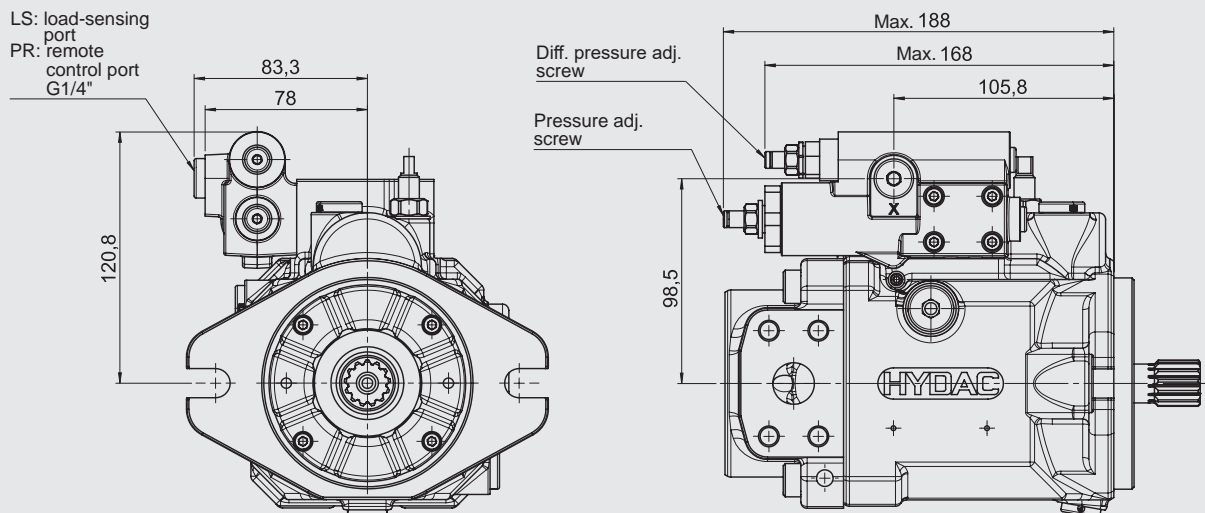

PPV100M28 with electrical displacement control ED

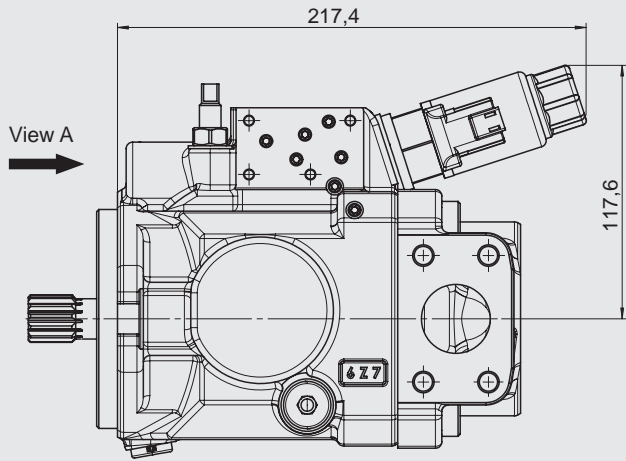

View A

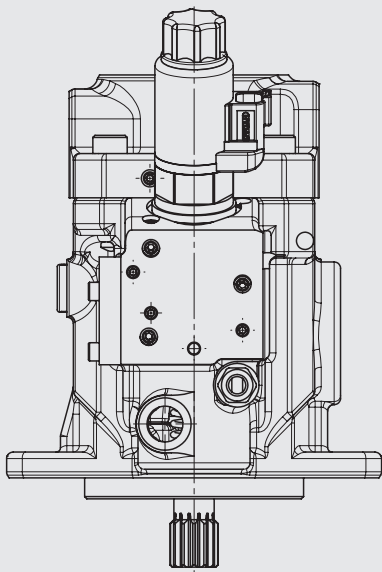
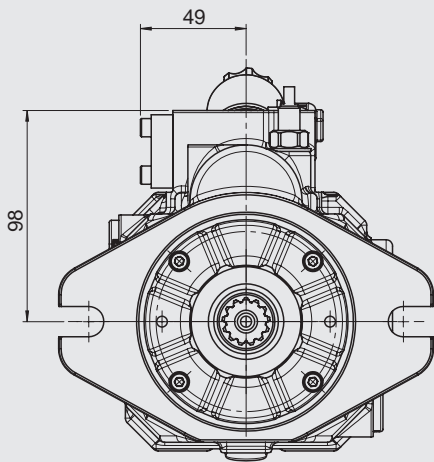

PPV100M28 with electrical displacement control and pressure control EDP

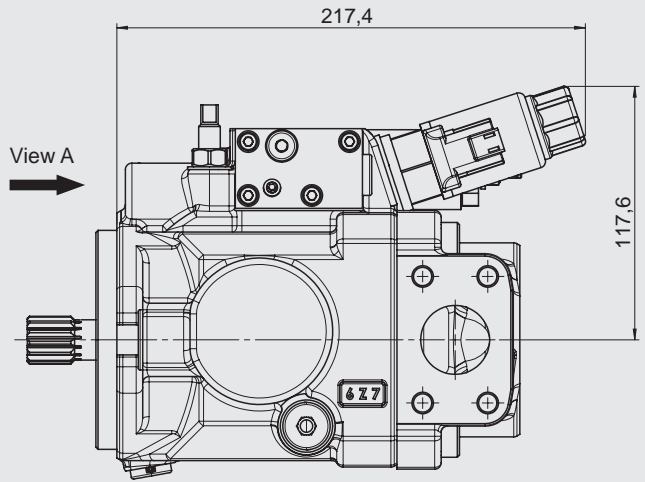

View A

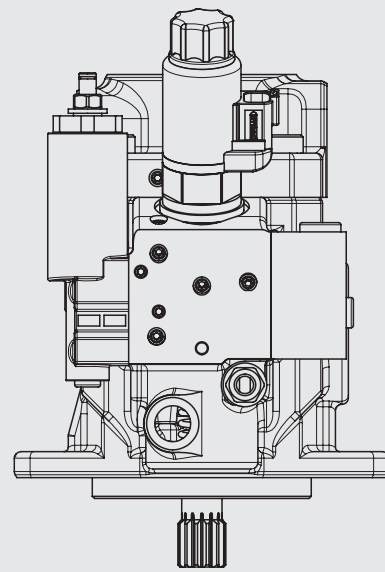
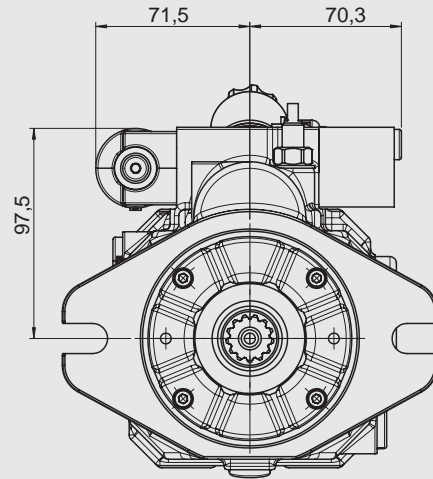

PPV100M28 with electrical displacement control and load-sensing control EDLS / EDLS0 / pressure remote control EDPR

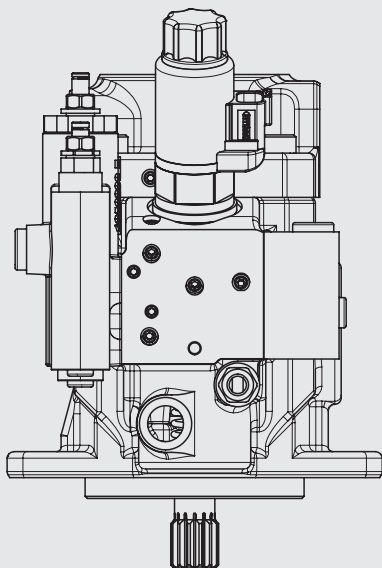
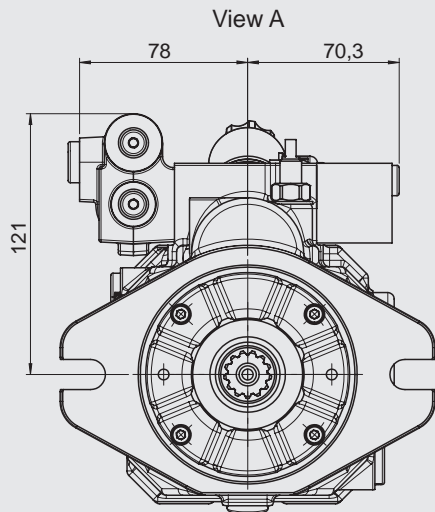
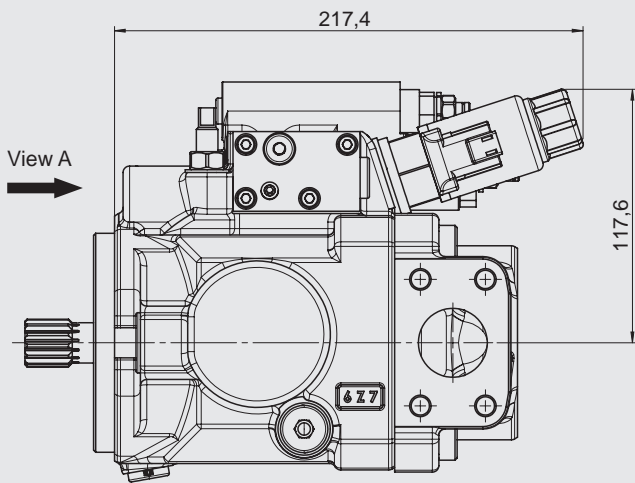

Dimensions PPV100M28 with swash angle sensor on request

PPV100M28 through drive options

Through drive SAE A

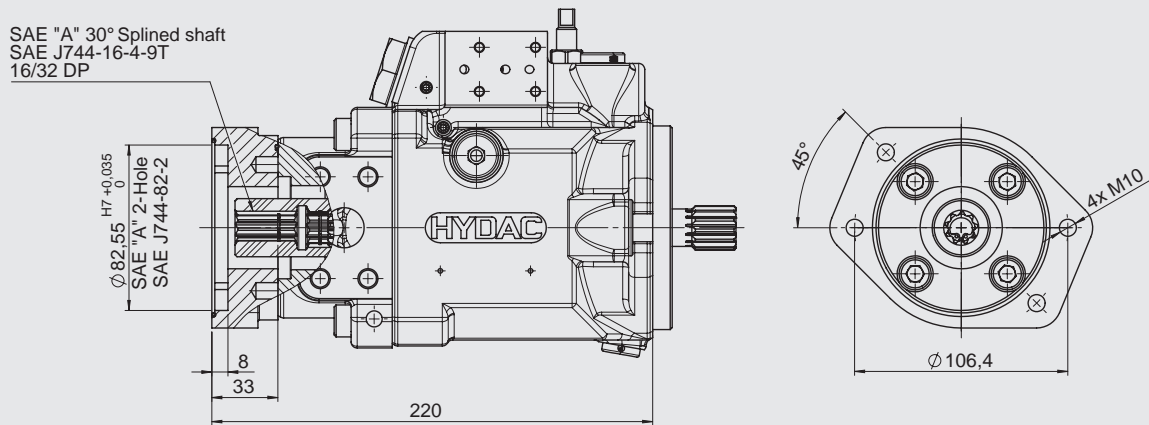

Through drive SAE AB

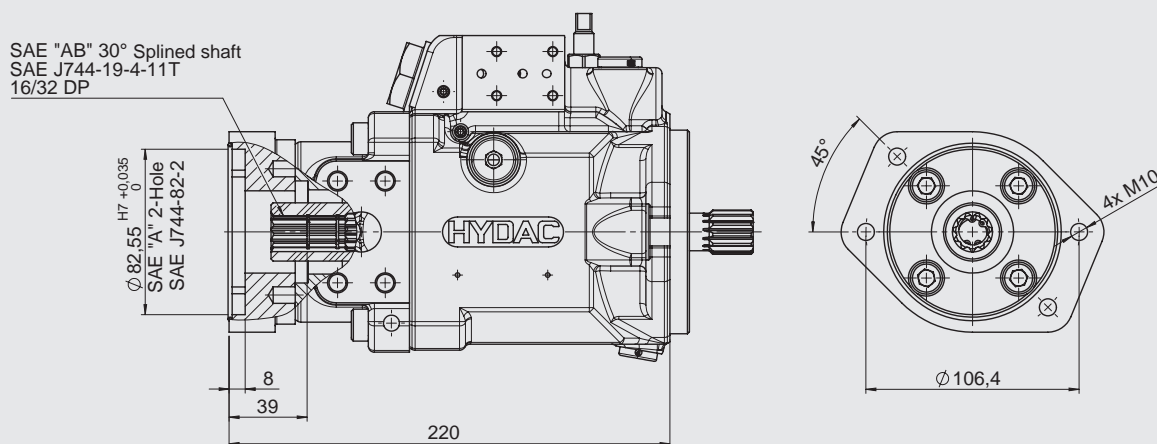

Through drive SAE B

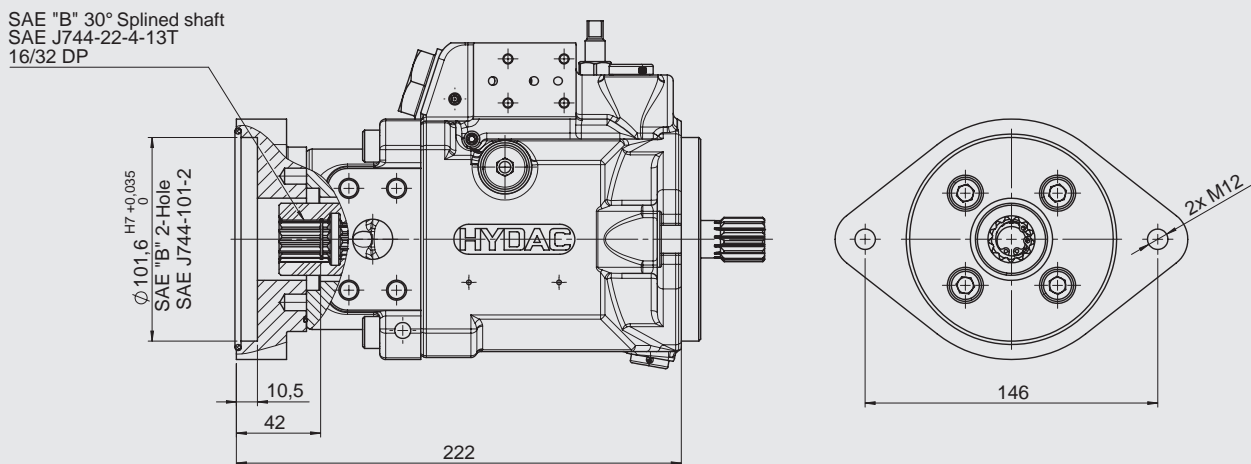

PPV100M45 clockwise rotation with pressure control P

(Notice: for anti-clockwise rotation, suction port and pressure port are reversed)

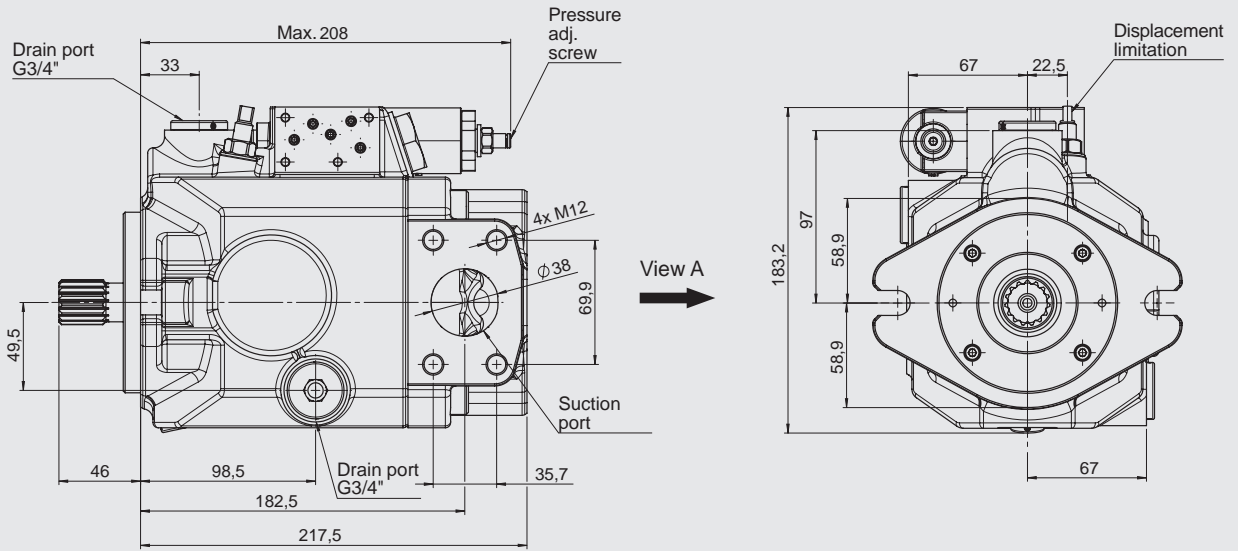

View A

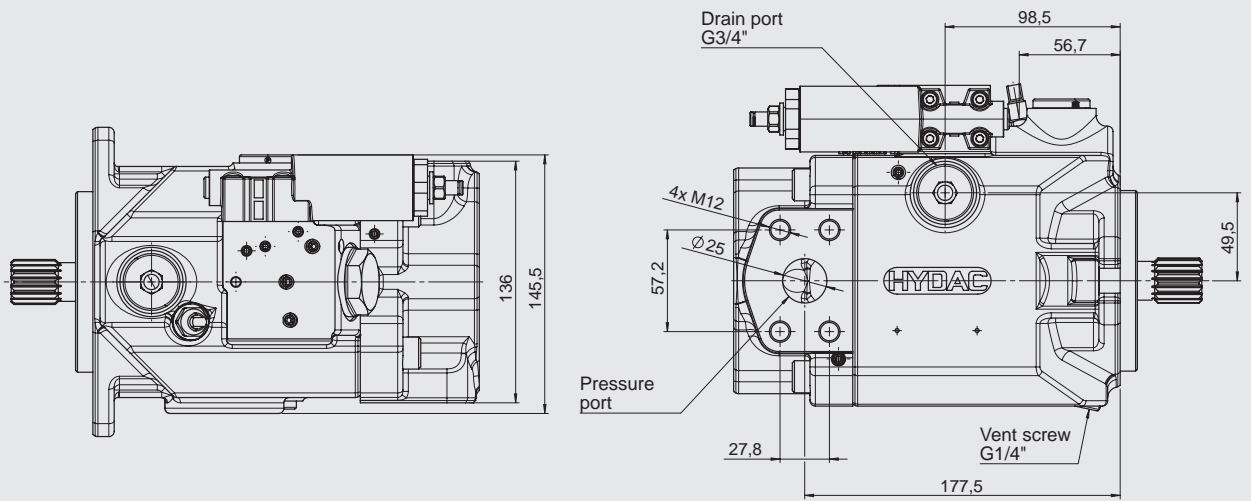

Mounting flange and shaft options

"B2" SAE B – 2-hole flange

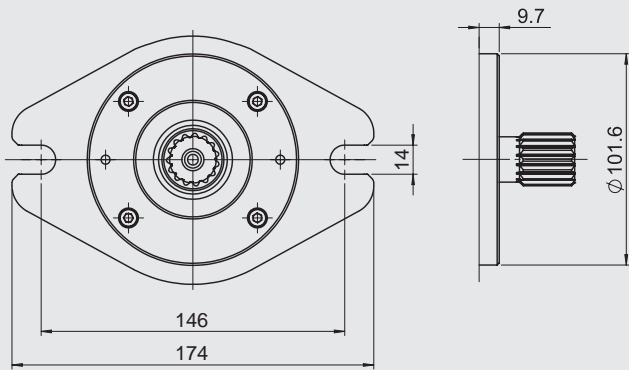

"S" SAE BB splined shaft

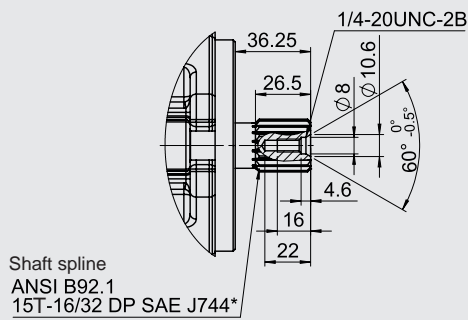

*30° pressure angle, flat root, side fit

"T" SAE BB splined shaft

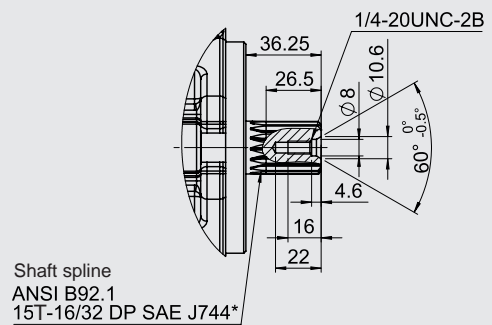

*30° pressure angle, flat root, side fit

"S1" SAE B splined shaft

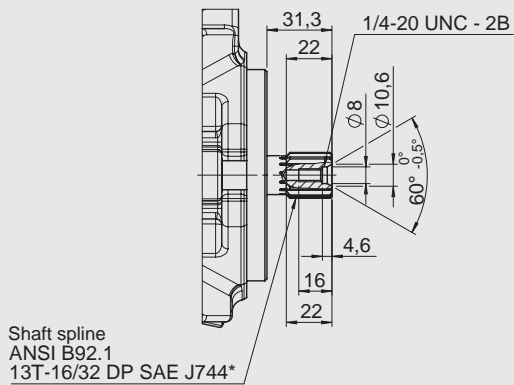

*30° pressure angle, flat root, side fit

"T1" SAE B splined shaft

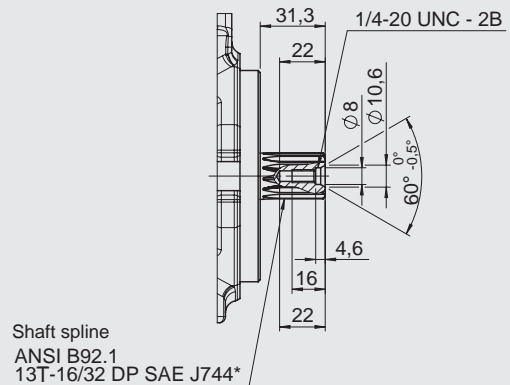

*30° pressure angle, flat root, side fit

PPV100M45 with load-sensing control LS / LS0 / pressure remote control PR

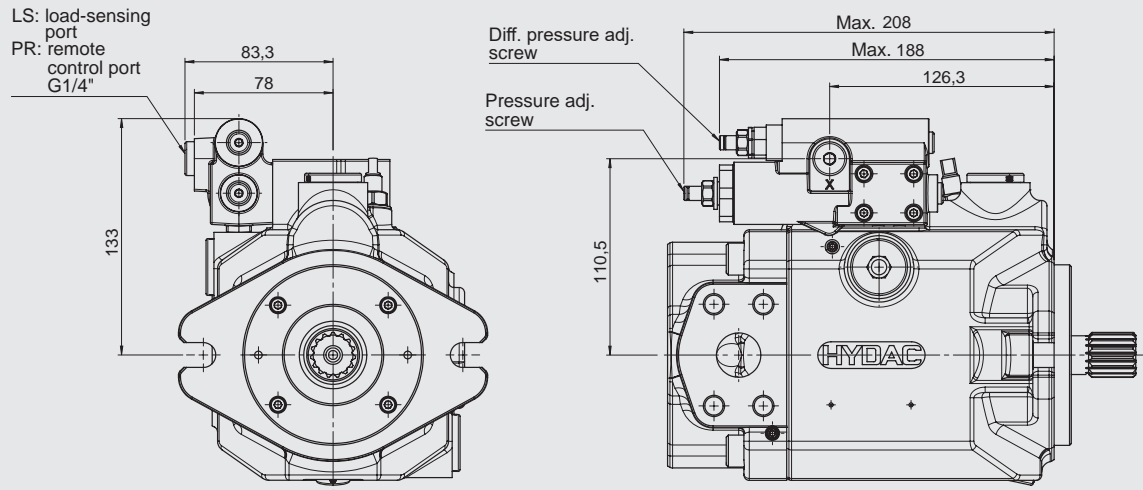

PPV100M45 with electrical displacement control ED

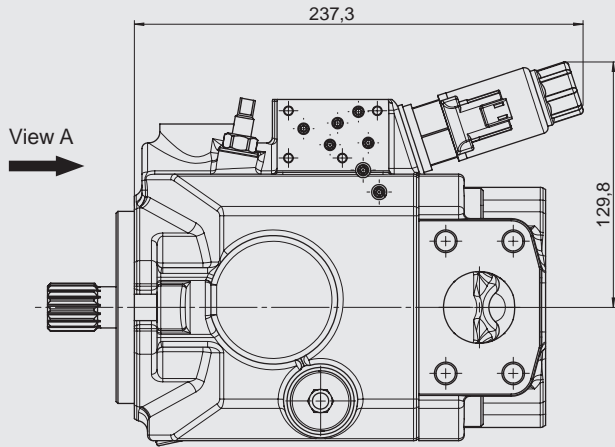

View A

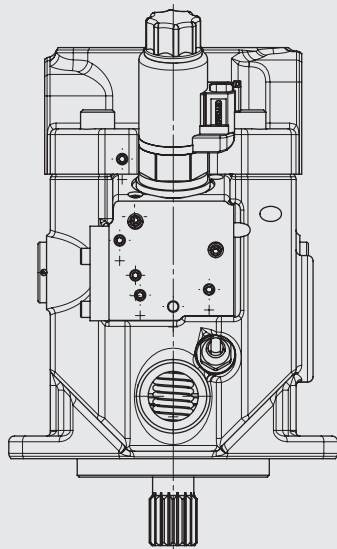
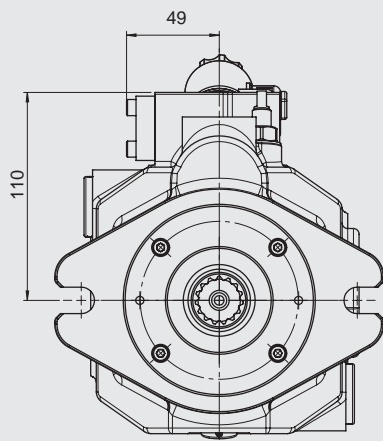

PPV100M45 with electrical displacement control and pressure control EDP

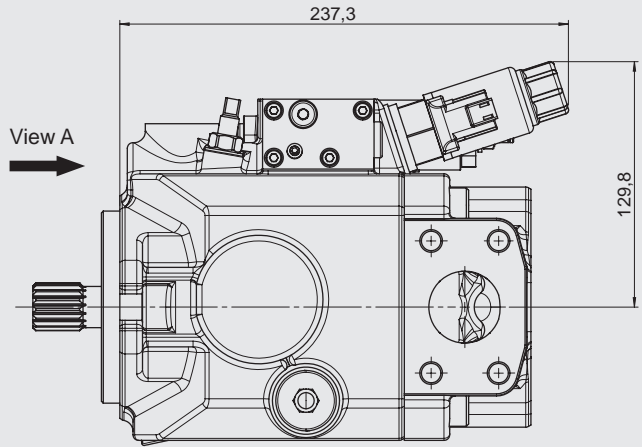

View A

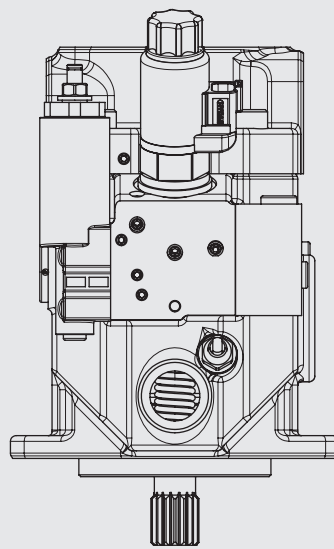
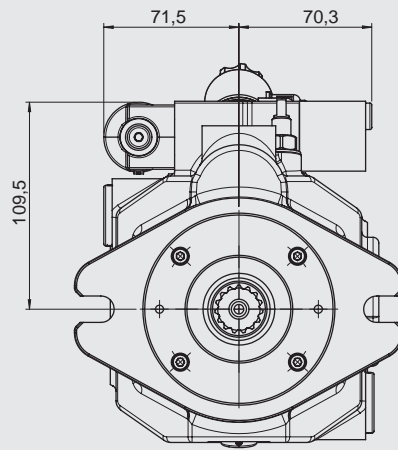

PPV100M45 with electrical displacement control and load-sensing control EDLS / EDLS0 / pressure remote control EDPR

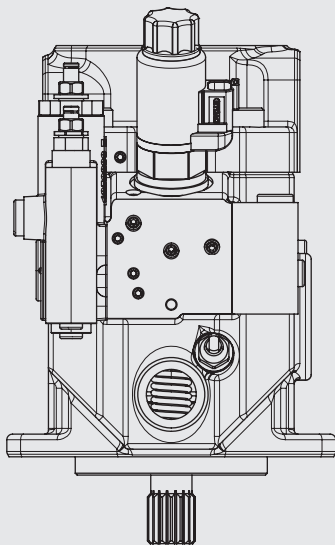
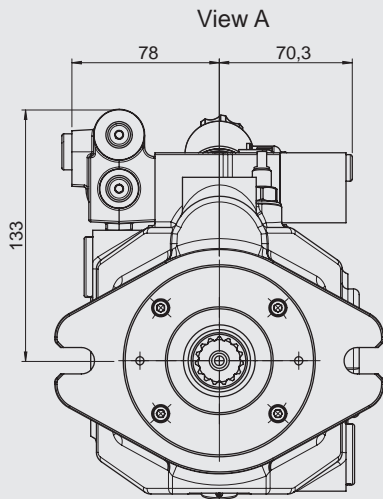
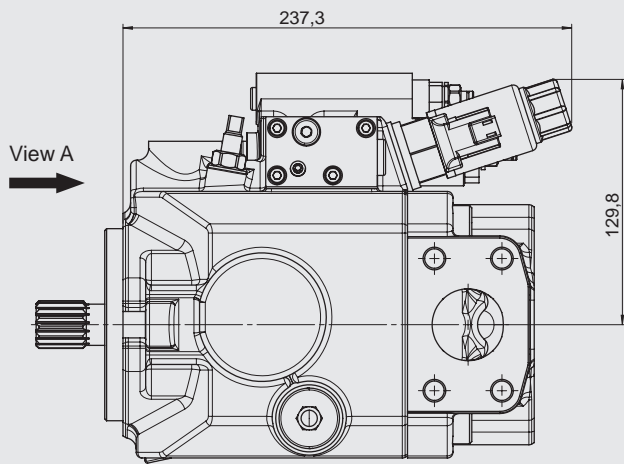

Dimensions PPV100M45 with swash angle sensor on request

PPV100M45 through drive options

Through drive SAE A

SAE "A" 30° Splined shaft
SAE J744-16-4-9T
16/32 DP

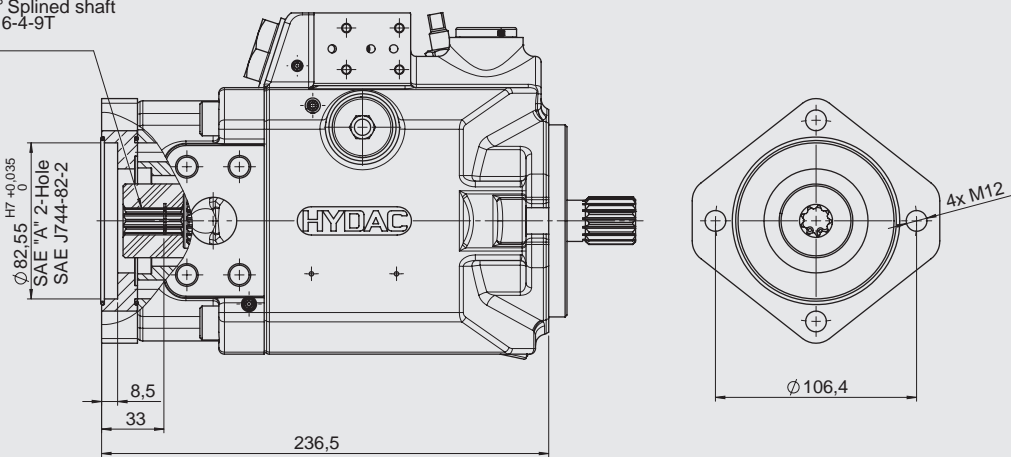

Through drive SAE AB

SAE "AB" 30° Splined shaft
SAE J744-19-4-11T
16/32 DP

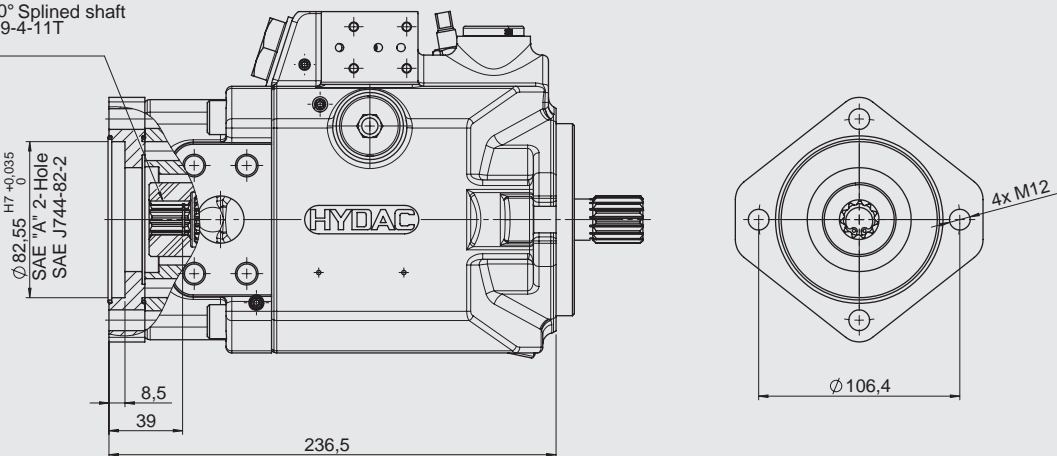

Through drive SAE AI

SAE "AB" 30° Splined shaft
SAE J744-19-4-11T
16/32 DP

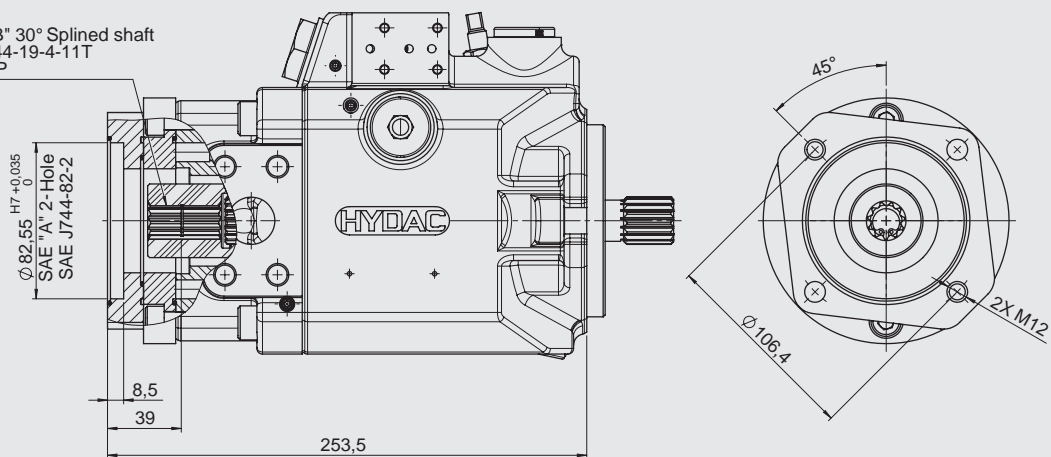

PPV100M45 through drive options

Through drive SAE B

SAE "B" 30° Splined shaft
SAE J744-22-4-13T
16/32 DP

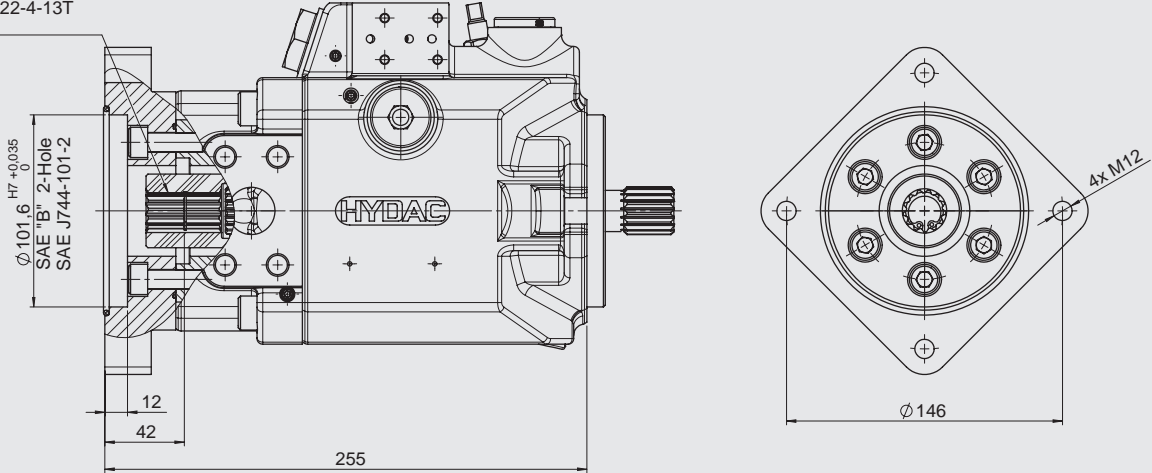

Through drive SAE BB

SAE "BB" 30° Splined shaft
SAE J744-25-4-15T
16/32 DP

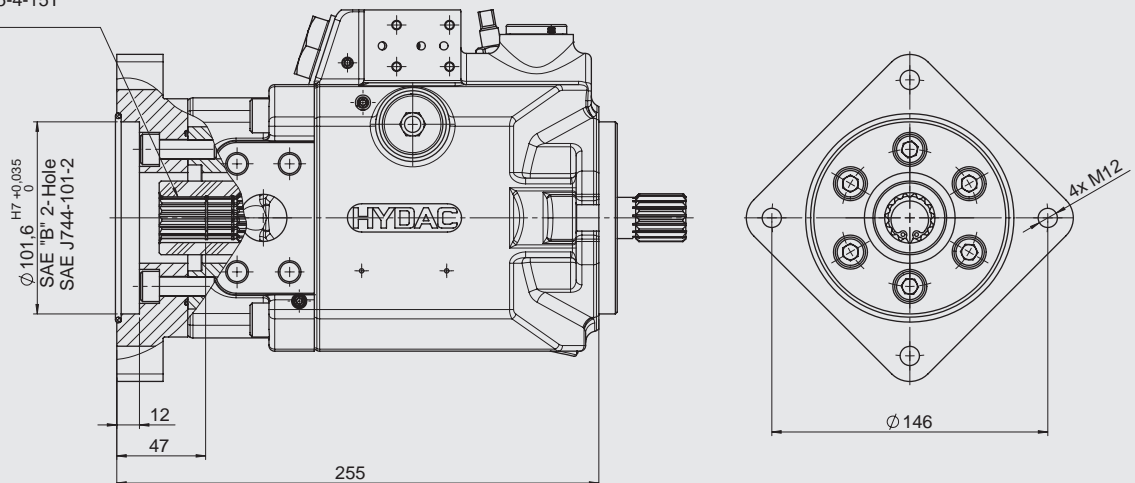

Through drive SAE C

SAE "C" 30° Splined shaft
SAE J744-32-4-14T
12/24 DP

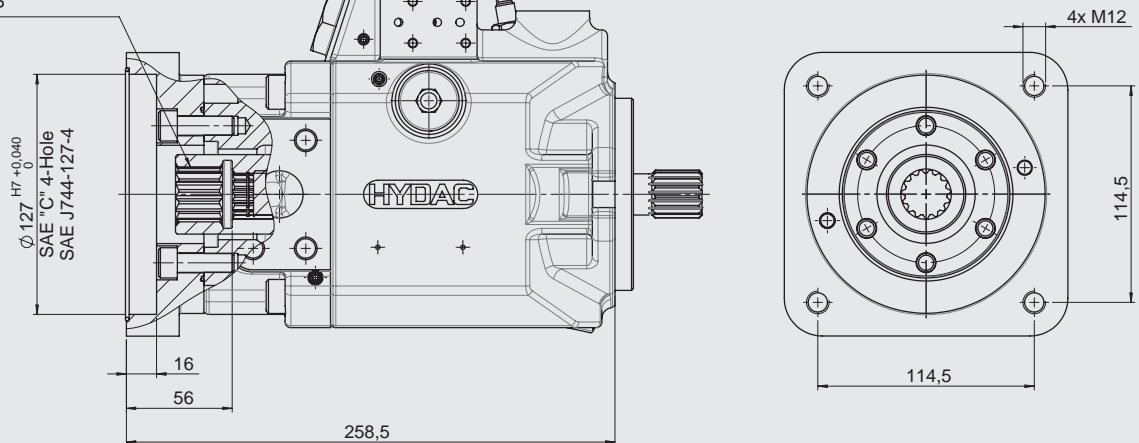

PPV100M63 clockwise rotation with pressure control P

(Notice: for anti-clockwise rotation, suction port and pressure port are reversed)

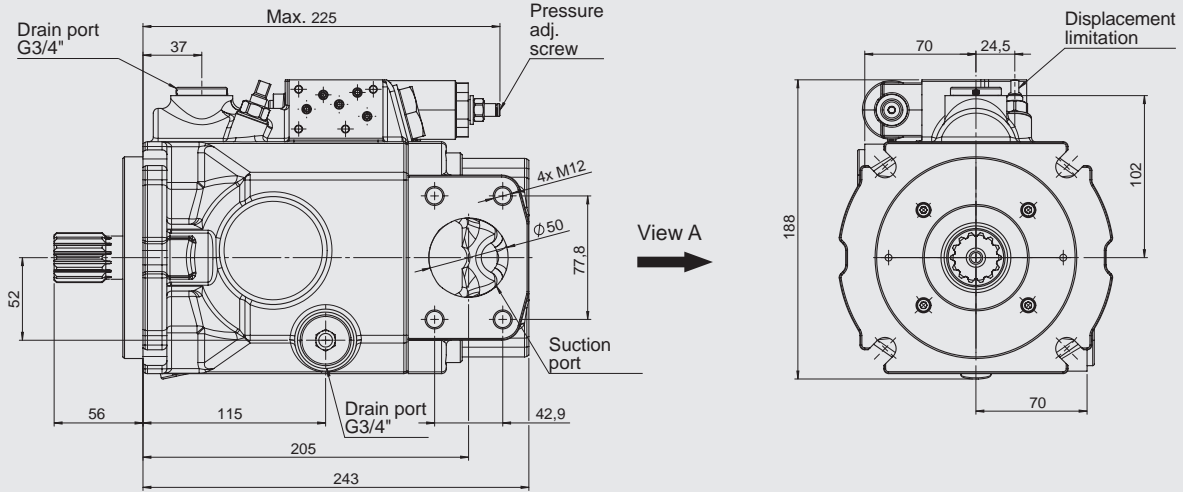

View A

View A

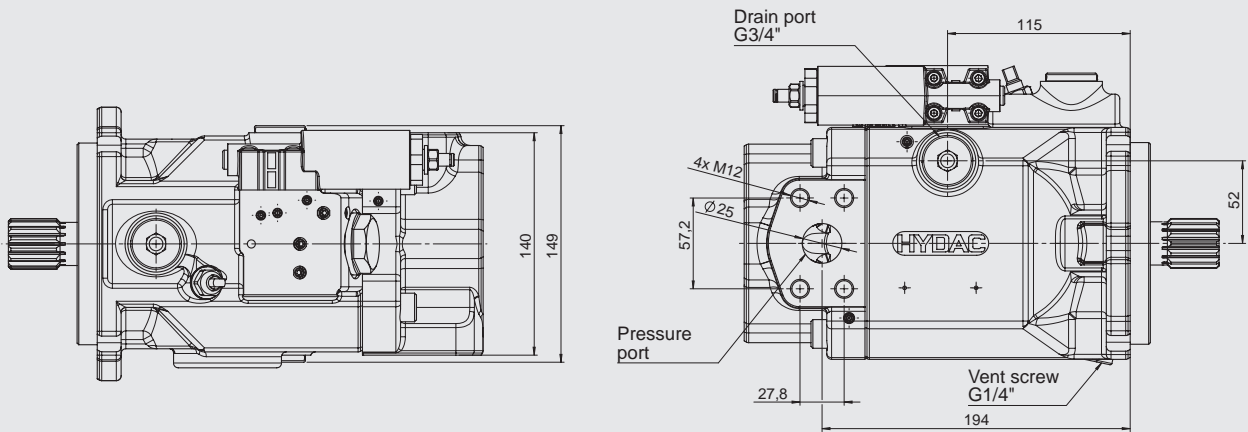

Mounting flange and shaft options

"B2" SAE B – 2-hole flange

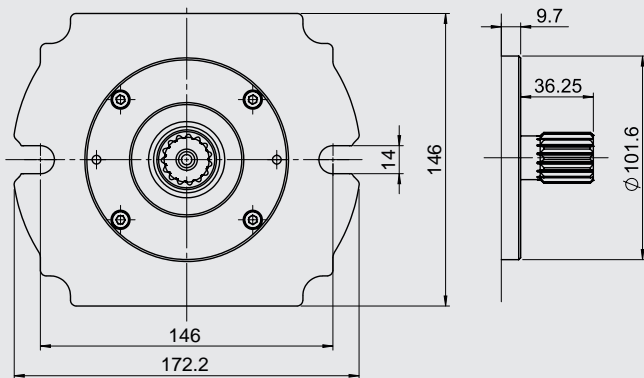

"C4" SAE C, 4-hole flange

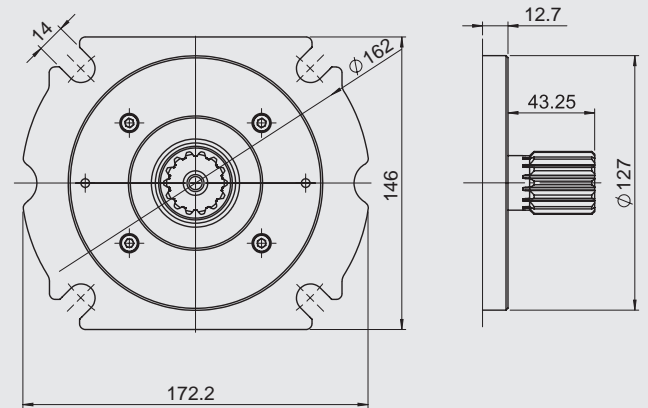

"S" SAE BB splined shaft

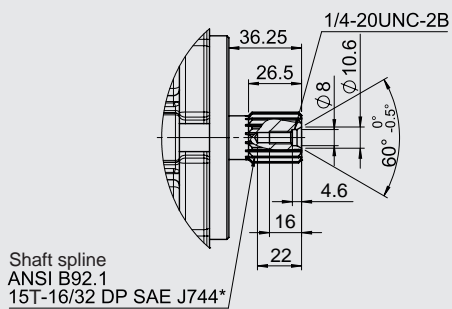

"S" SAE C splined shaft

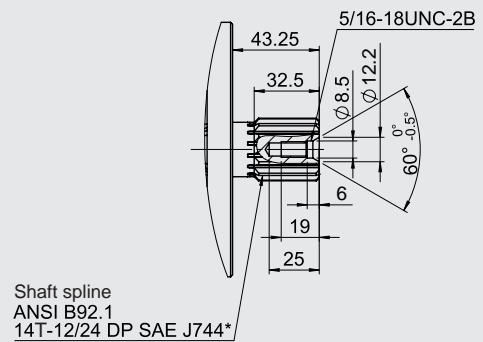

*30° pressure angle, flat root, side fit

*30° pressure angle, flat root, side fit

"T" SAE BB splined shaft

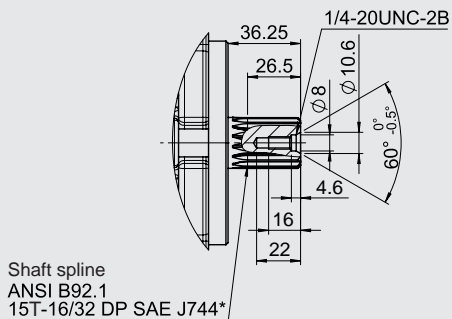

"T" SAE C splined shaft

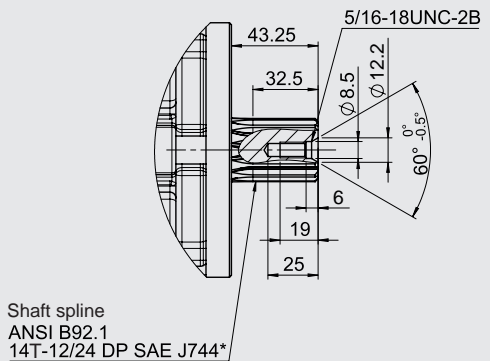

*30° pressure angle, flat root, side fit

*30° pressure angle, flat root, side fit

PPV100M63 with load-sensing control LS / LS0 / pressure remote control PR

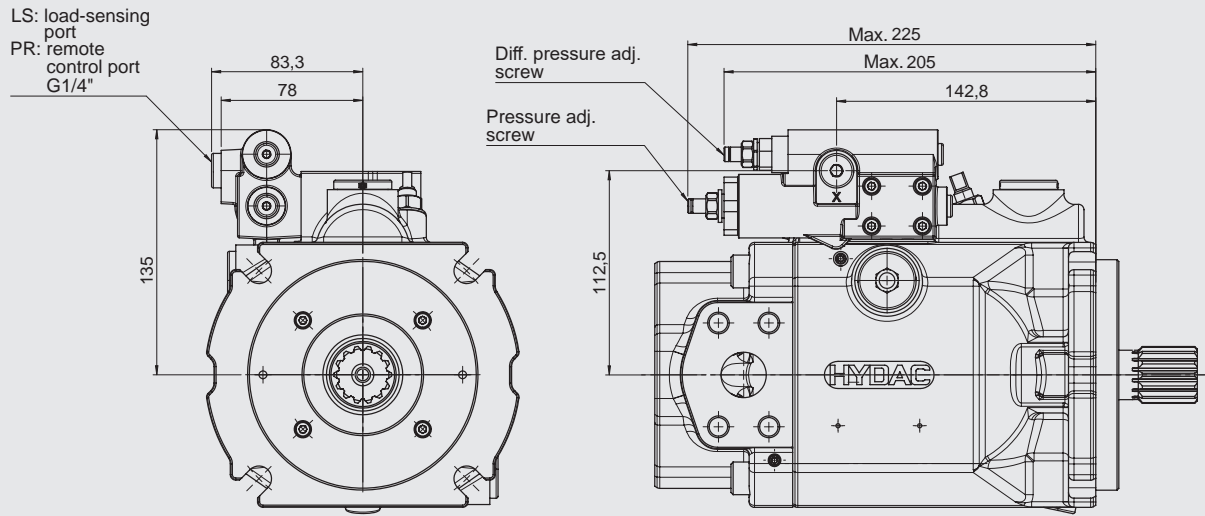

PPV100M63 with electrical displacement control ED

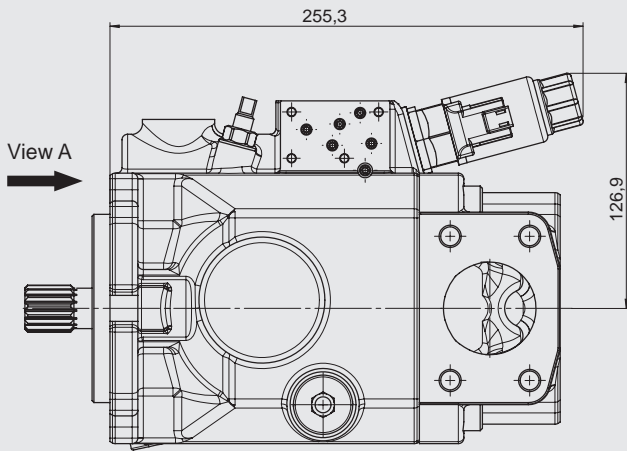

View A

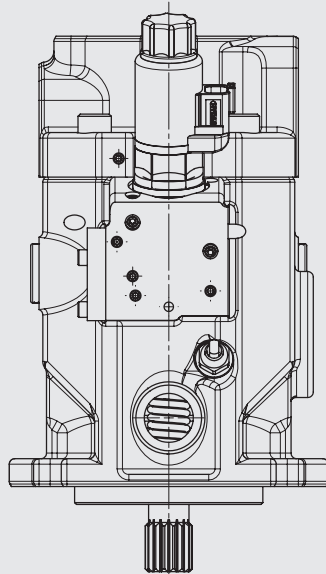
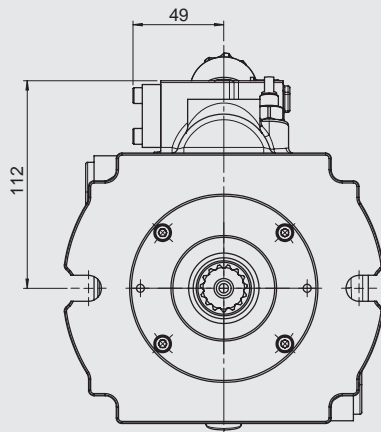

PPV100M63 with electrical displacement control and pressure control EDP

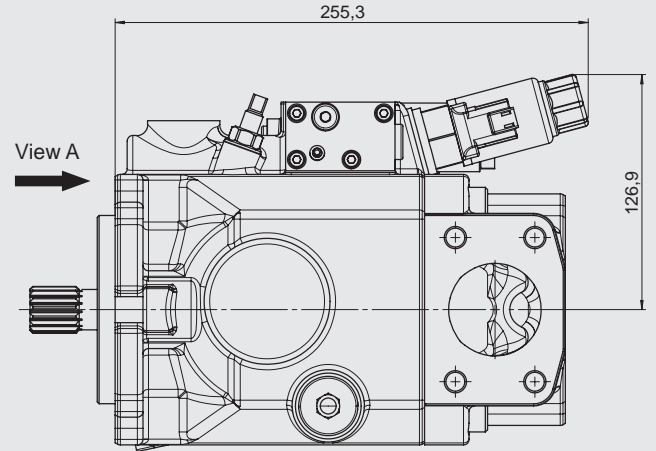

View A

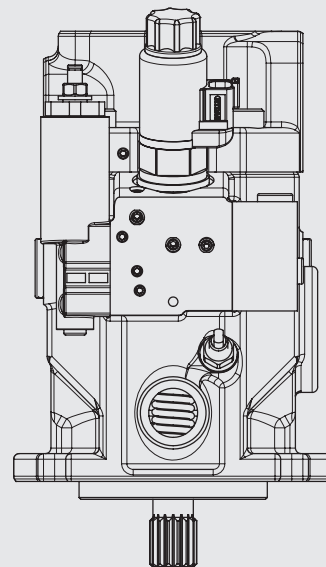
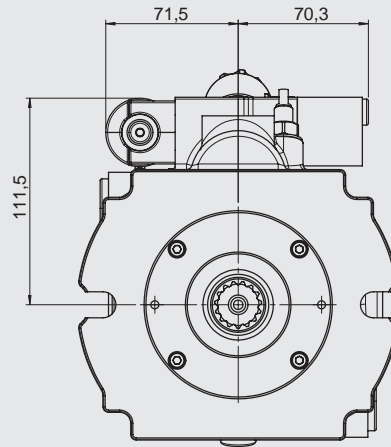

PPV100M63 with electrical displacement control and load-sensing control EDLS / EDLS0 / pressure remote control EDPR

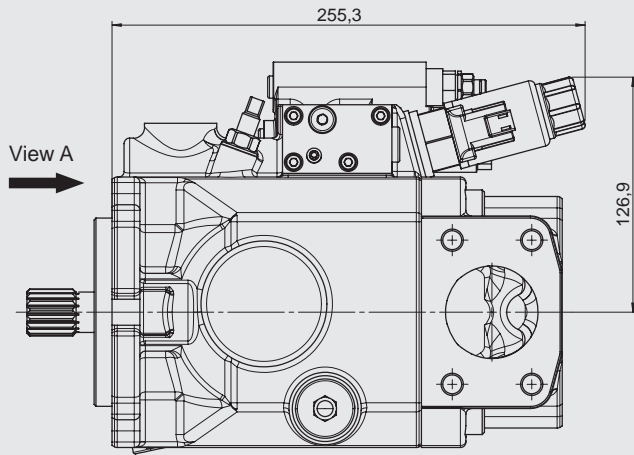

View A

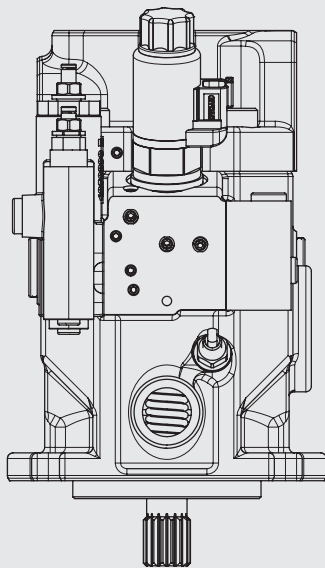
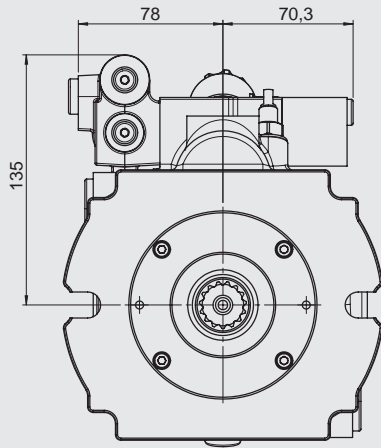

Dimensions PPV100M63 with swash angle sensor on request

PPV100M63 through drive options

Through drive SAE A

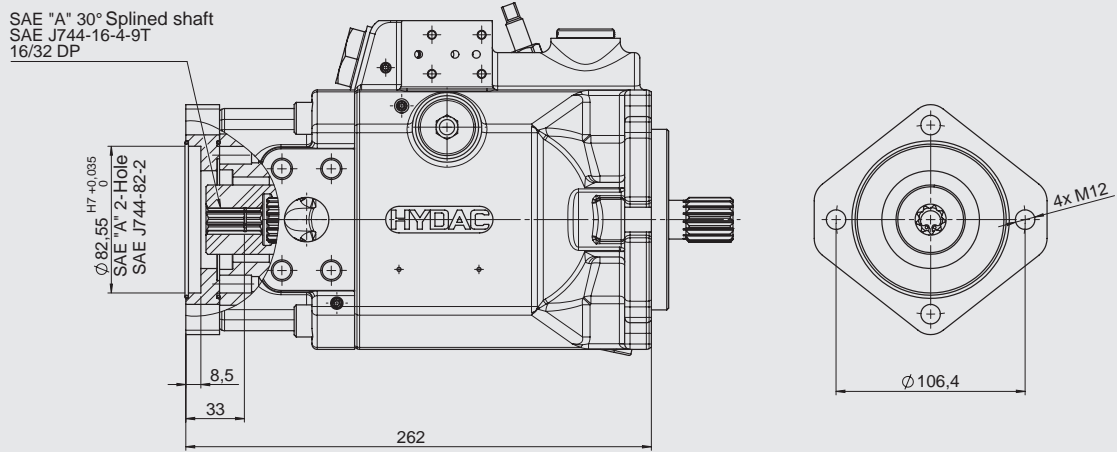

Through drive SAE AB

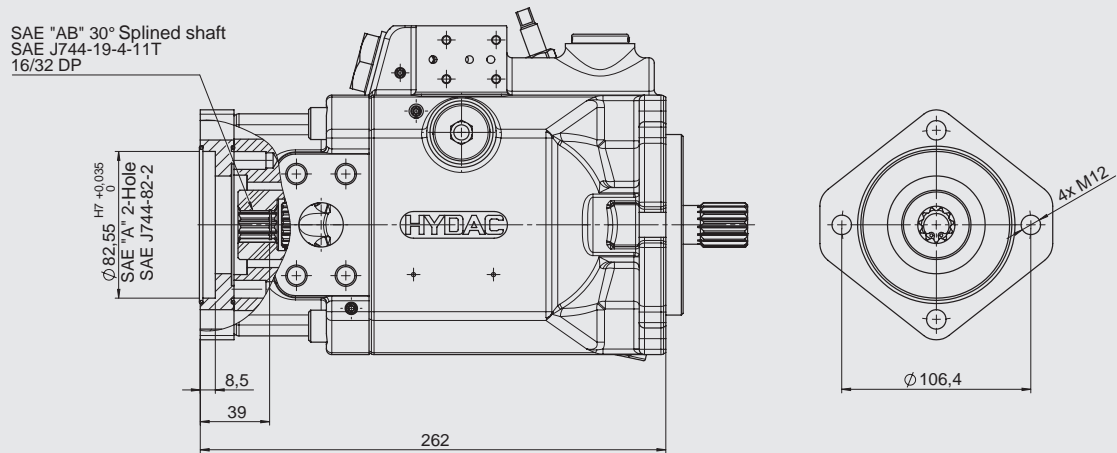

Through drive SAE AI

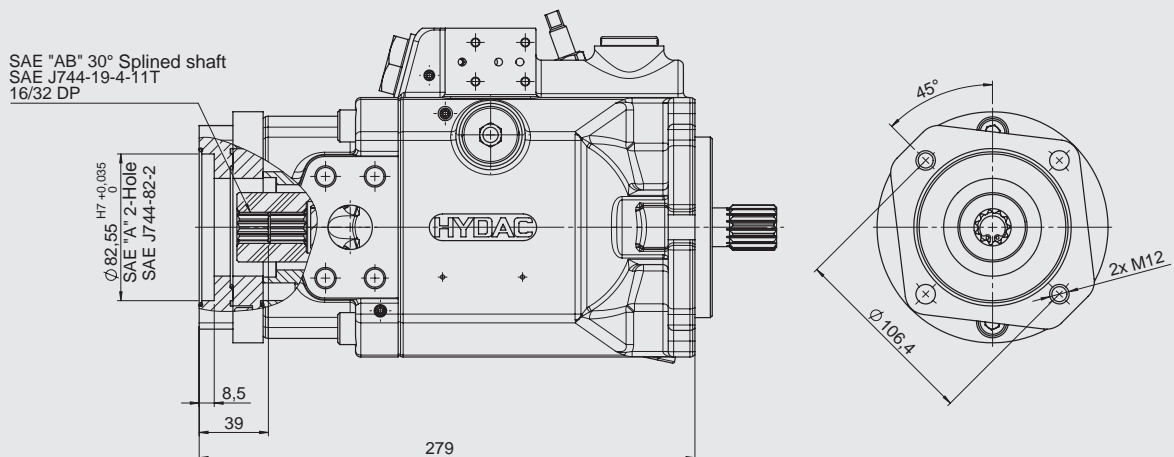

PPV100M63 through drive options

Through drive SAE B

SAE "B" 30° Splined shaft
SAE J744-22-4-13T
16/32 DP

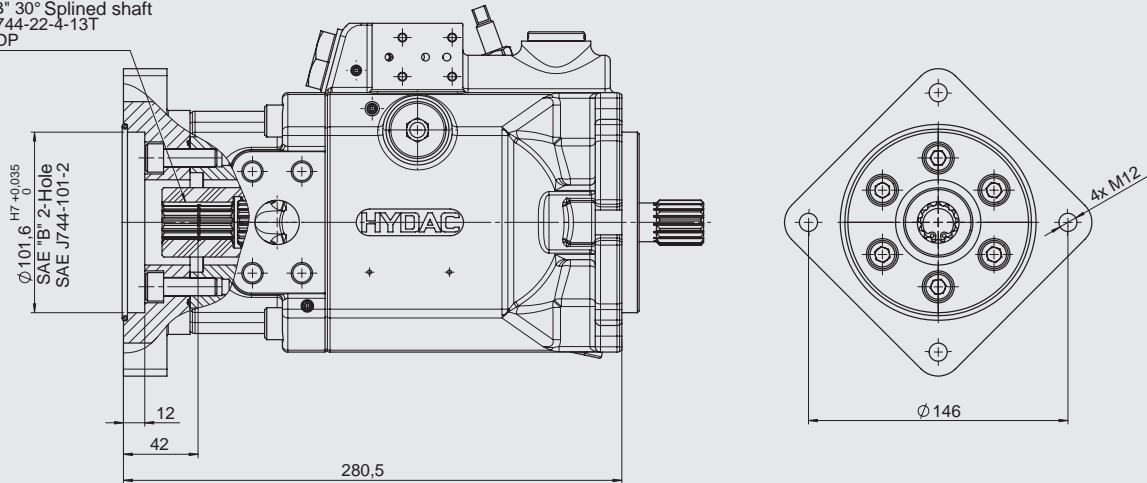

Through drive SAE BB

SAE "BB" 30° Splined shaft
SAE J744-25-4-15T
16/32 DP

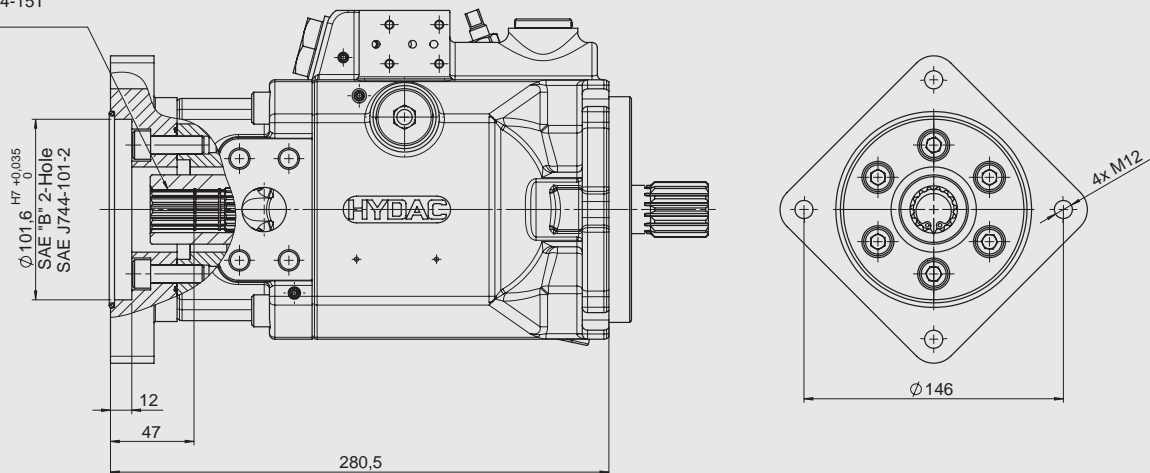

Through drive SAE C

SAE "C" 30° Splined shaft
SAE J744-32-4-14T
12/24 DP

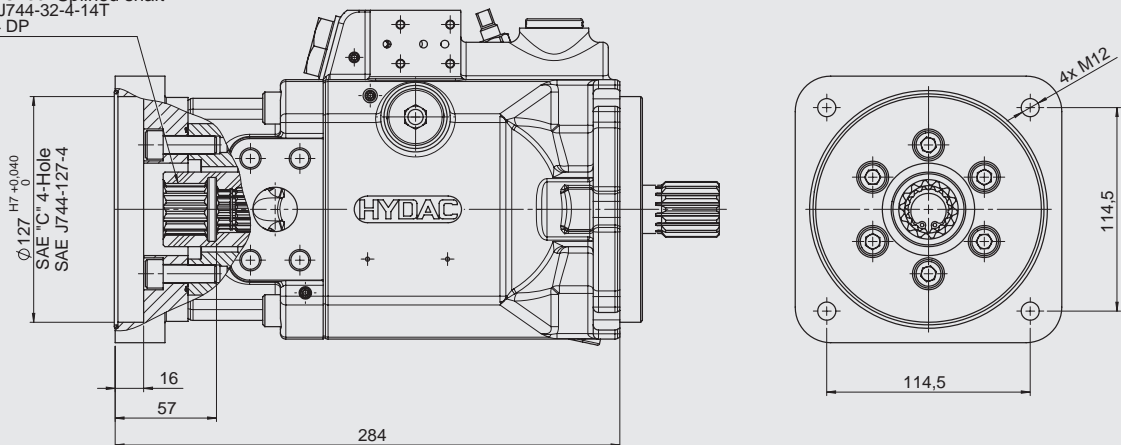

PPV100M85 / PPV100M100 clockwise rotation with pressure control P
 (Notice: for anti-clockwise rotation, suction port and pressure port are reversed)

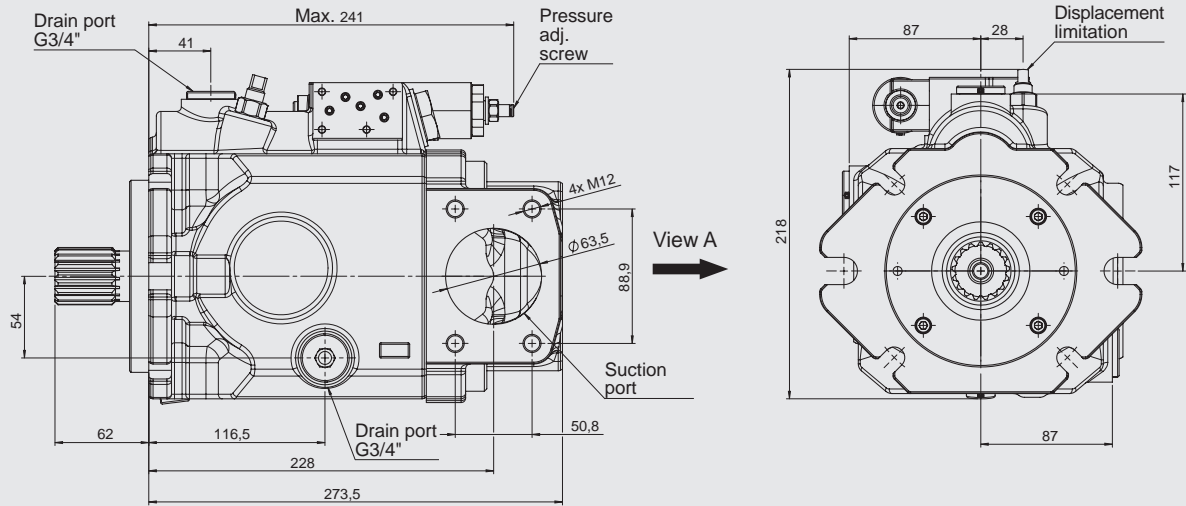

View A

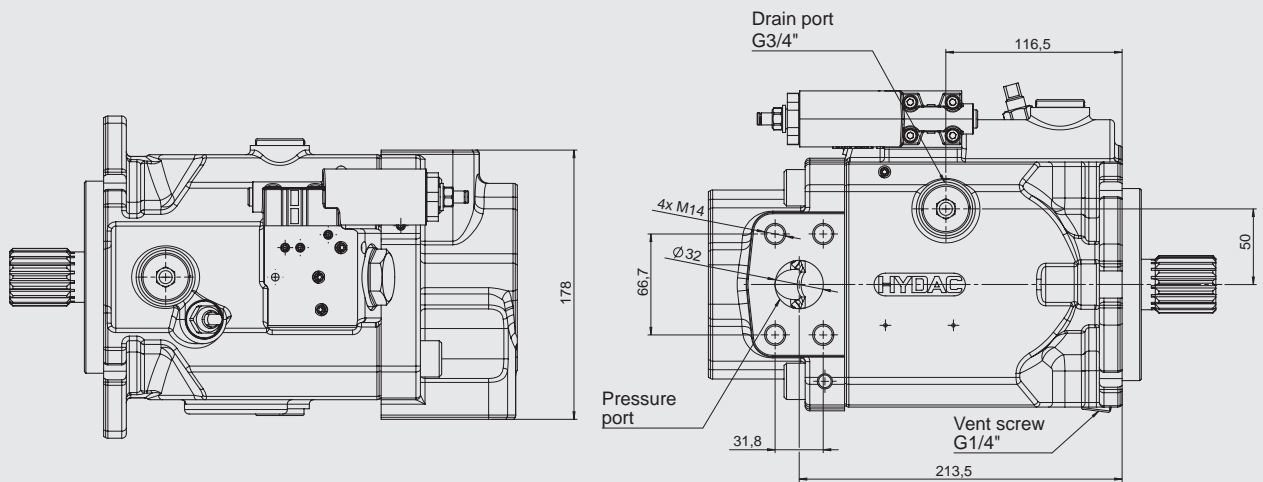

Mounting flange and shaft options

"C5" SAE C, 2/4-hole flange

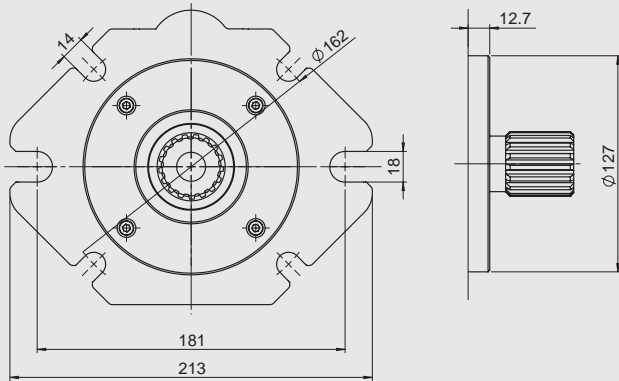

"S" SAE CC splined shaft

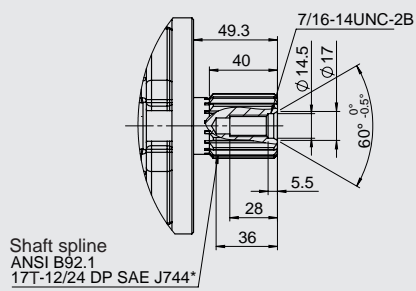

*30° pressure angle, flat root, side fit

"S1" SAE C splined shaft

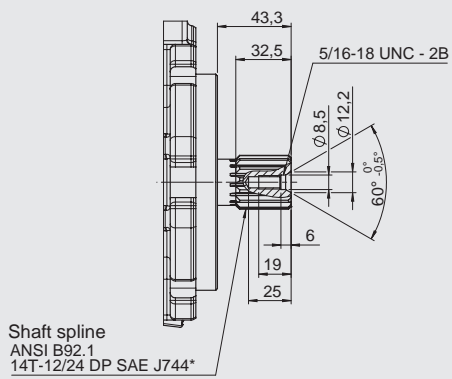

*30° pressure angle, flat root, side fit

"T1" SAE C splined shaft

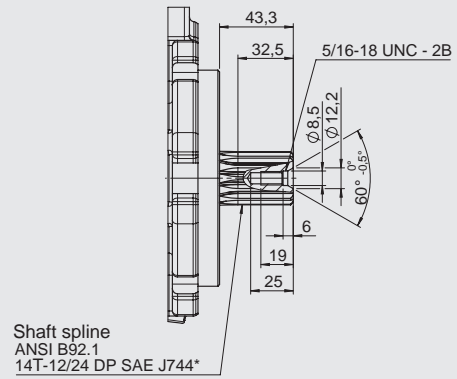

*30° pressure angle, flat root, side fit

PPV100M85 / PPV100M100 with load-sensing control LS / LS0 / pressure remote control PR

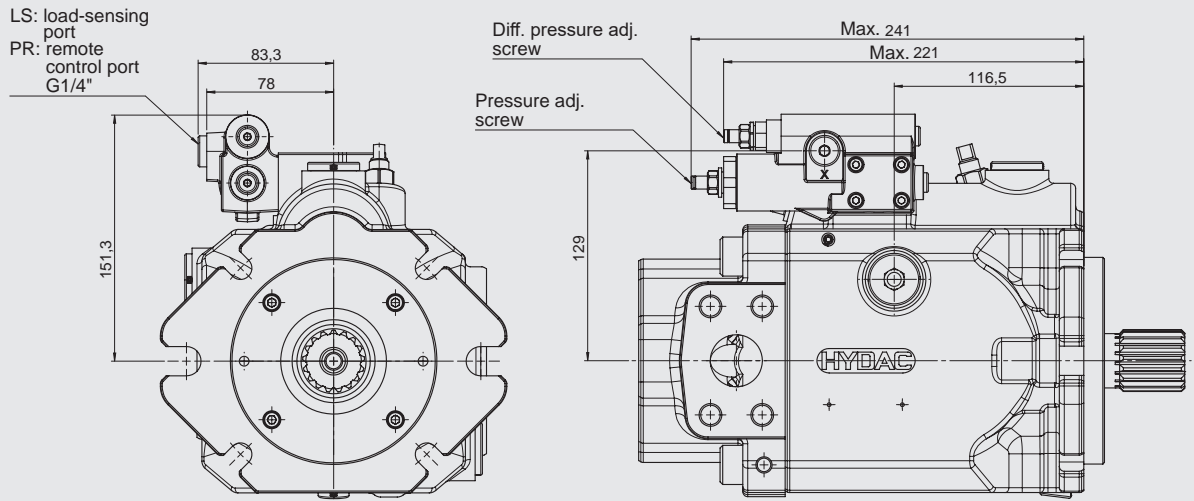

PPV100M85 / PPV100M100 with electrical displacement control ED

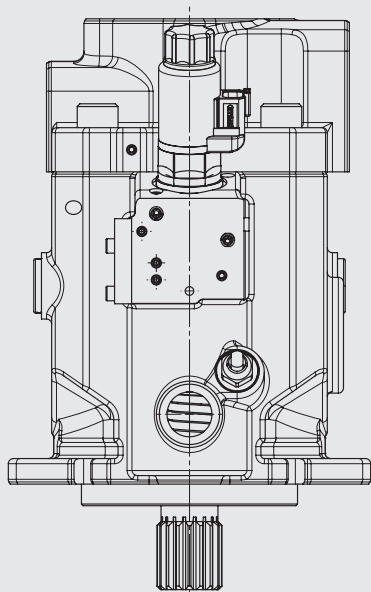
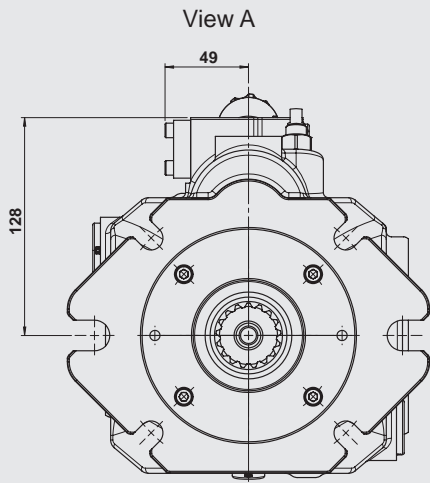
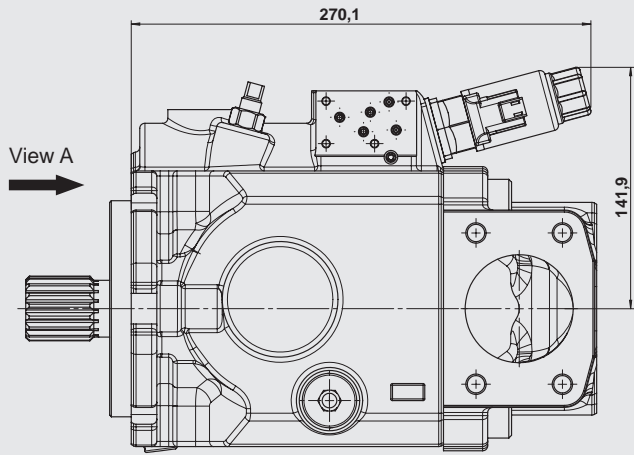

PPV100M85 / PPV100M100 with electrical displacement control and pressure control EDP

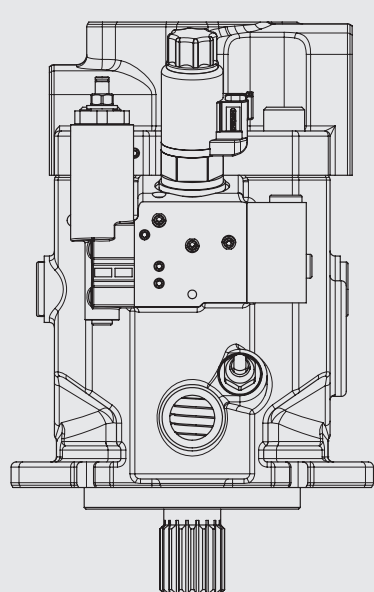
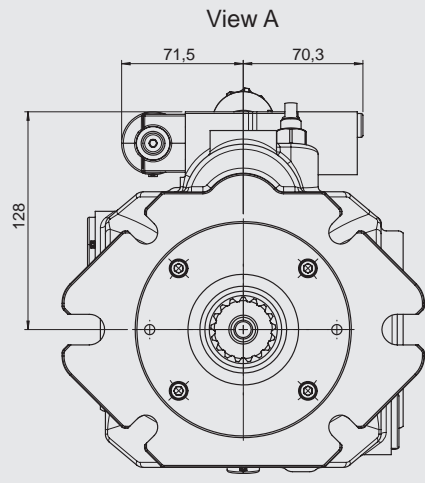
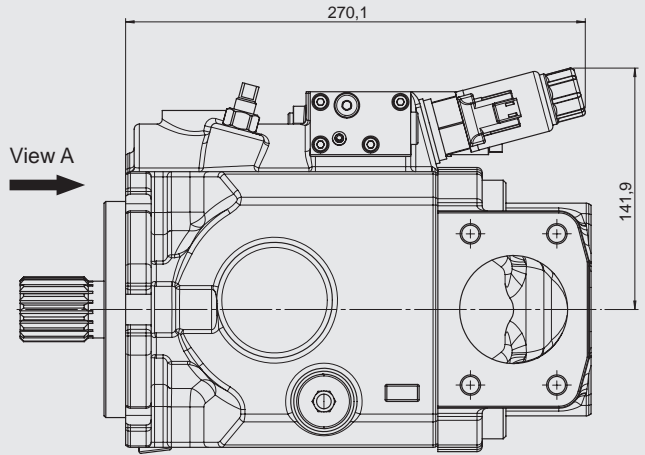

PPV100M85 / PPV100M100 with electrical displacement control and load-sensing control EDLS / EDLS0 / pressure remote control EDPR

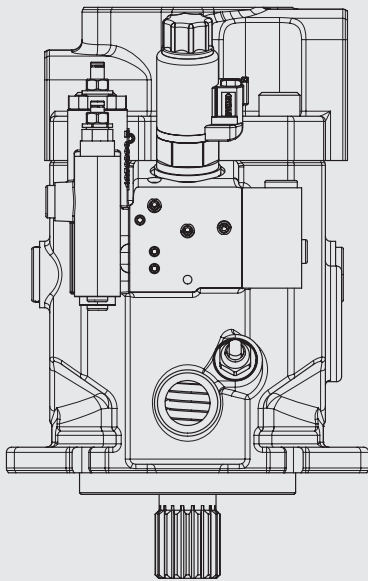
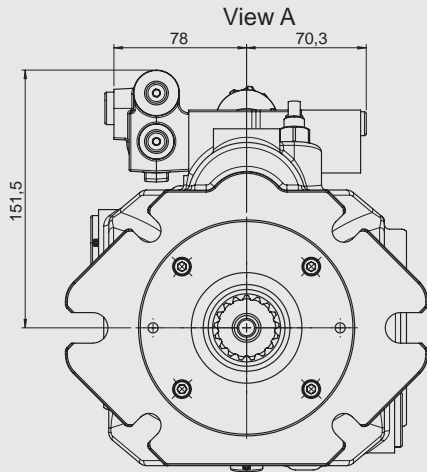
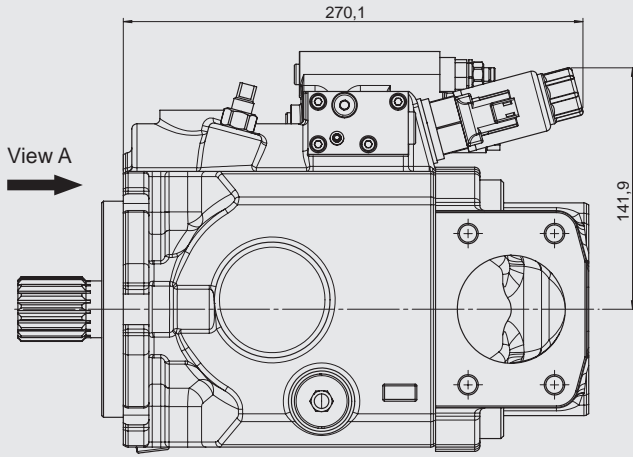

Dimensions PPV100M85/PPV100M100 with swash angle sensor on request

PPV100M85 / PPV100M100 through drive options

Through drive SAE A

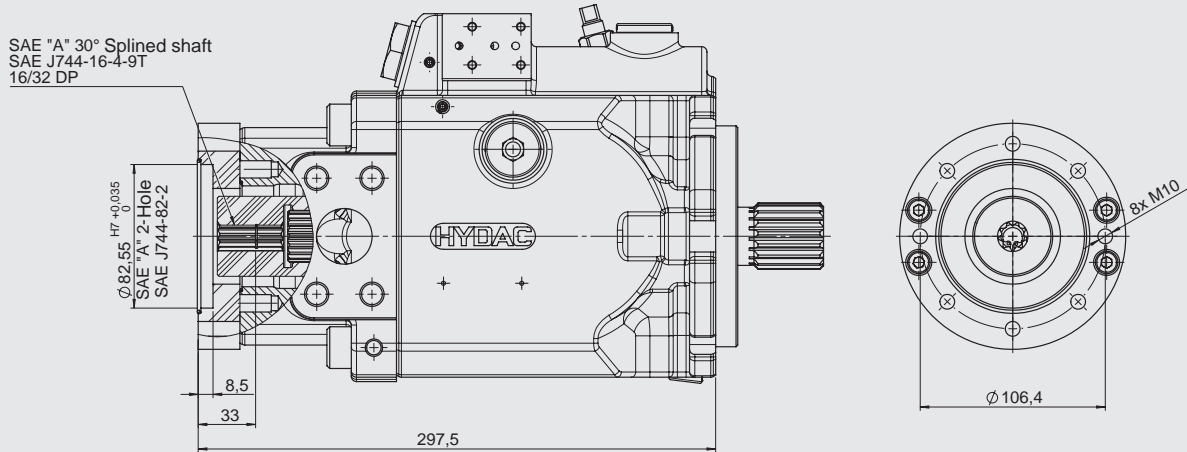

Through drive SAE AB

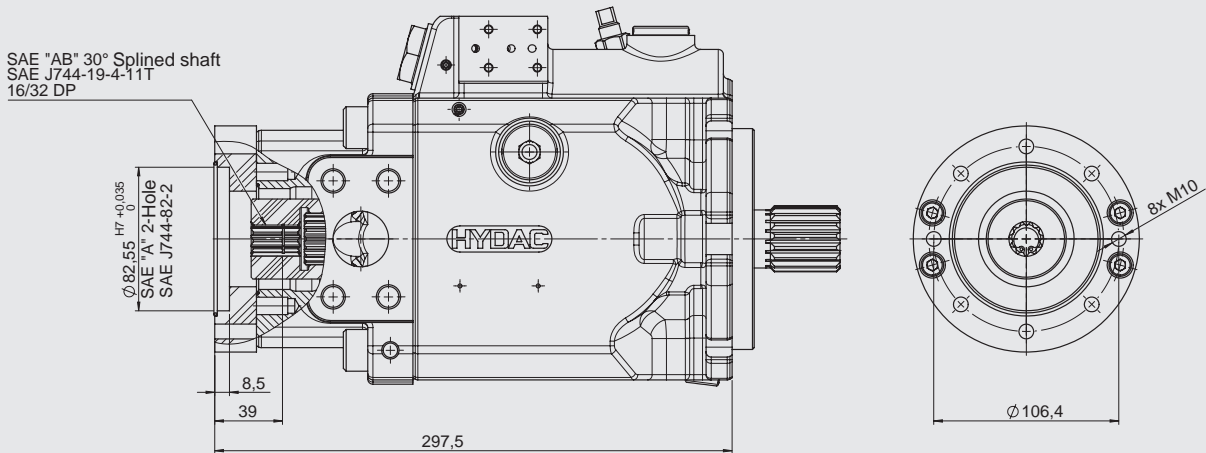

Through drive SAE B

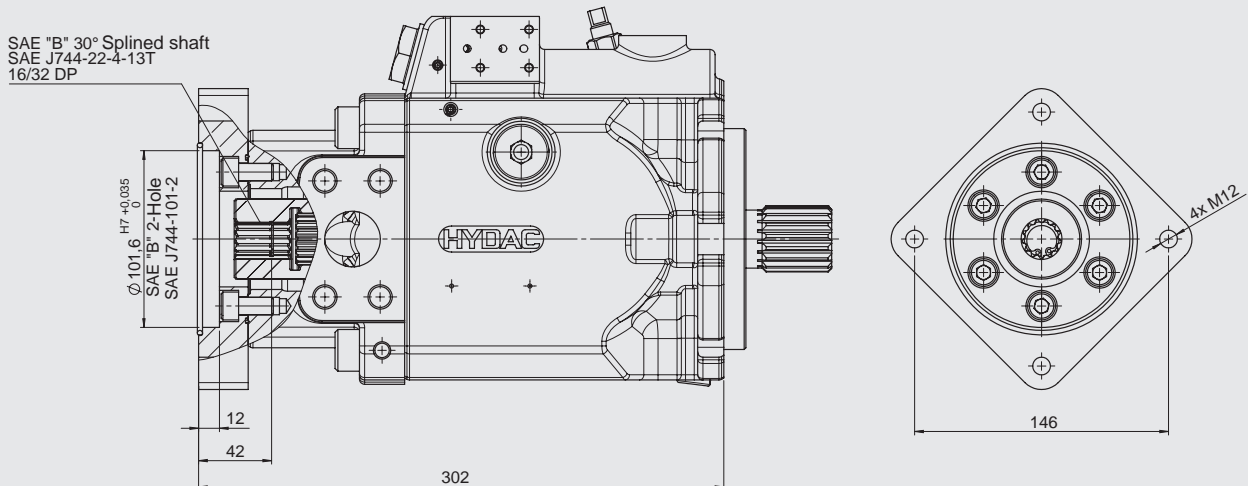

PPV100M85 / PPV100M100 through drive options

Through drive SAE BB

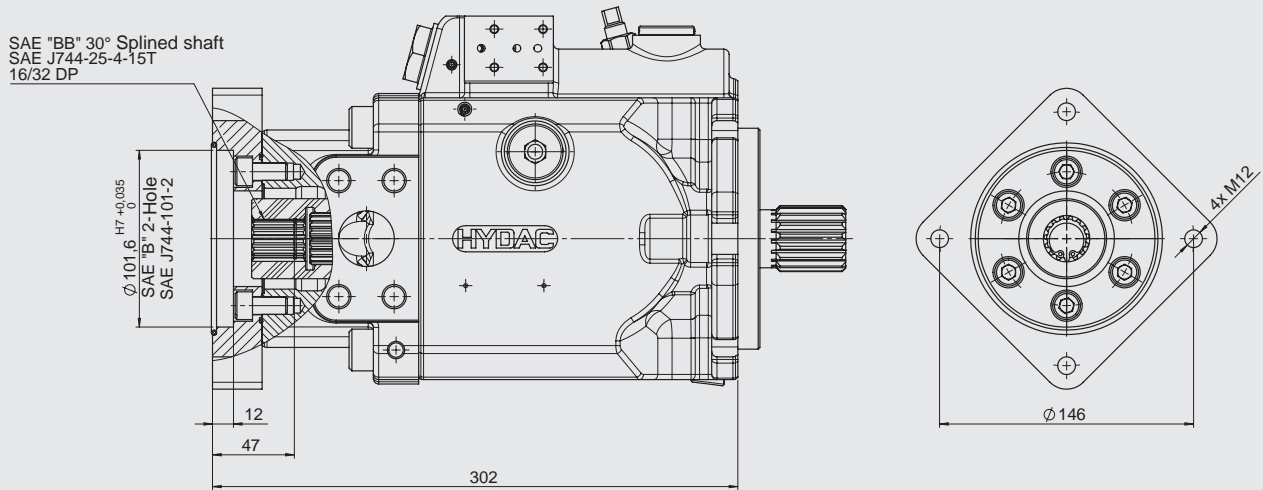

Through drive SAE C

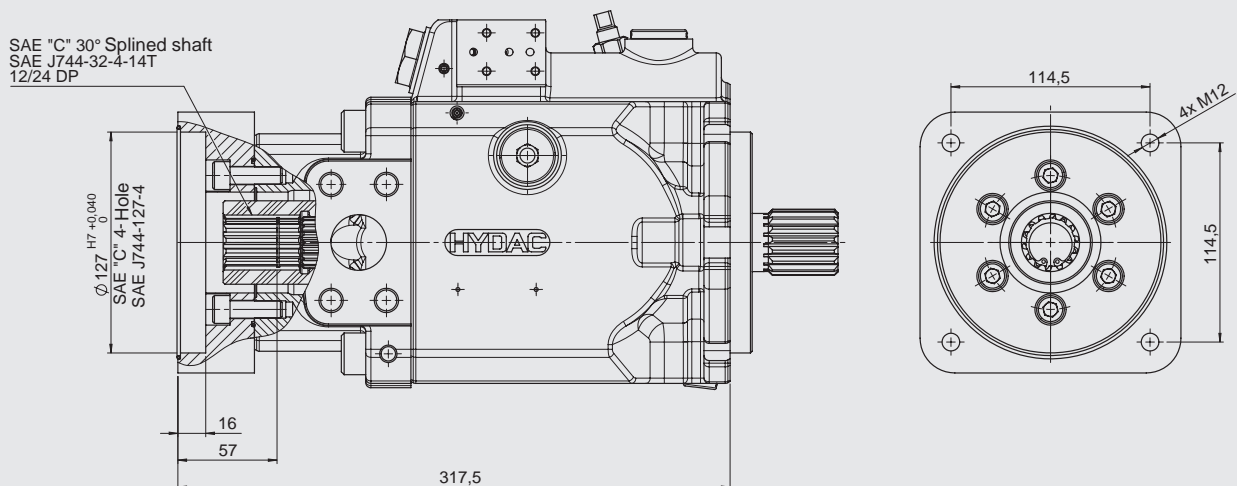

Through drive SAE CC

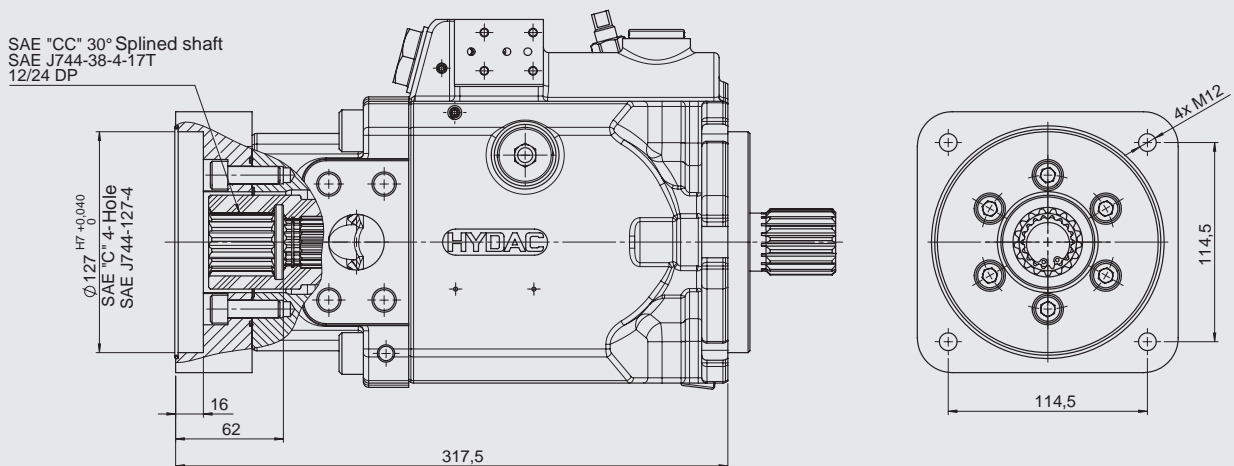

5.6 Connectors for sensors

The swash angle sensor is fitted with an AMP connector as standard.

3-pin AMP Superseal 1.5

Protection class: IP67 acc. to DIN EN 60529

Connection type: 3-pin connector

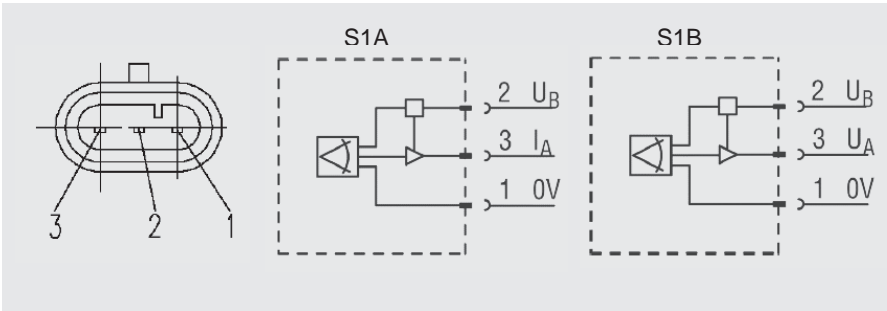

The pressure sensor is also available with a Deutsch connector (DT04-3P) or a DIN connector (M12x1).

Version K – Deutsch DT04-3P

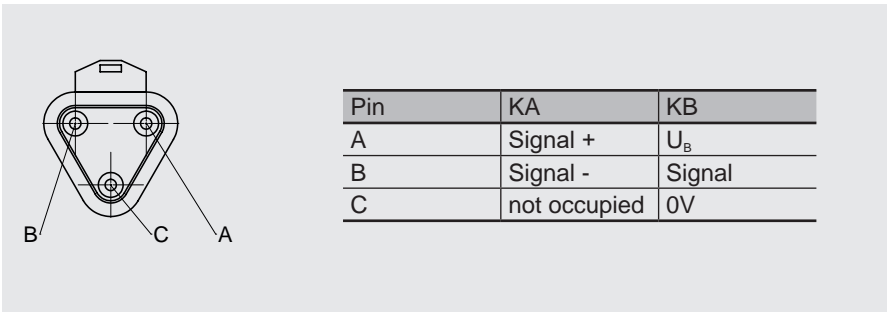

Version 6 - M12x1

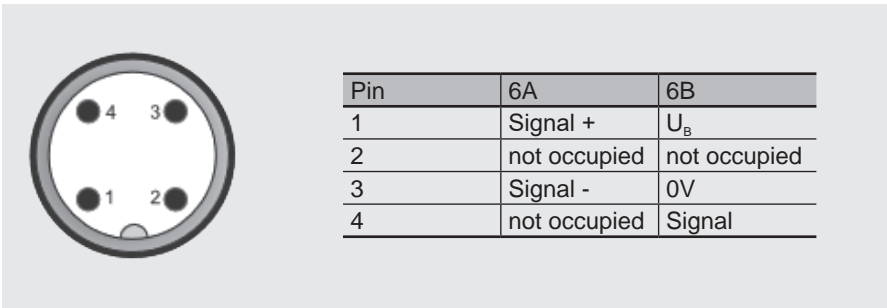

A large grid of graph paper for taking notes, consisting of 20 columns and 30 rows of small squares.



Accumulators 30.000



Filter Technology 70.000



Process Technology 77.000



Filter Systems 79.000



Compact Hydraulics 53.000

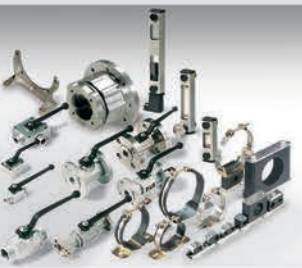

Accessories 61.000



Electronics 180.000



Cooling Systems 57.000

Global presence.
Local competence.
www.hydac.com

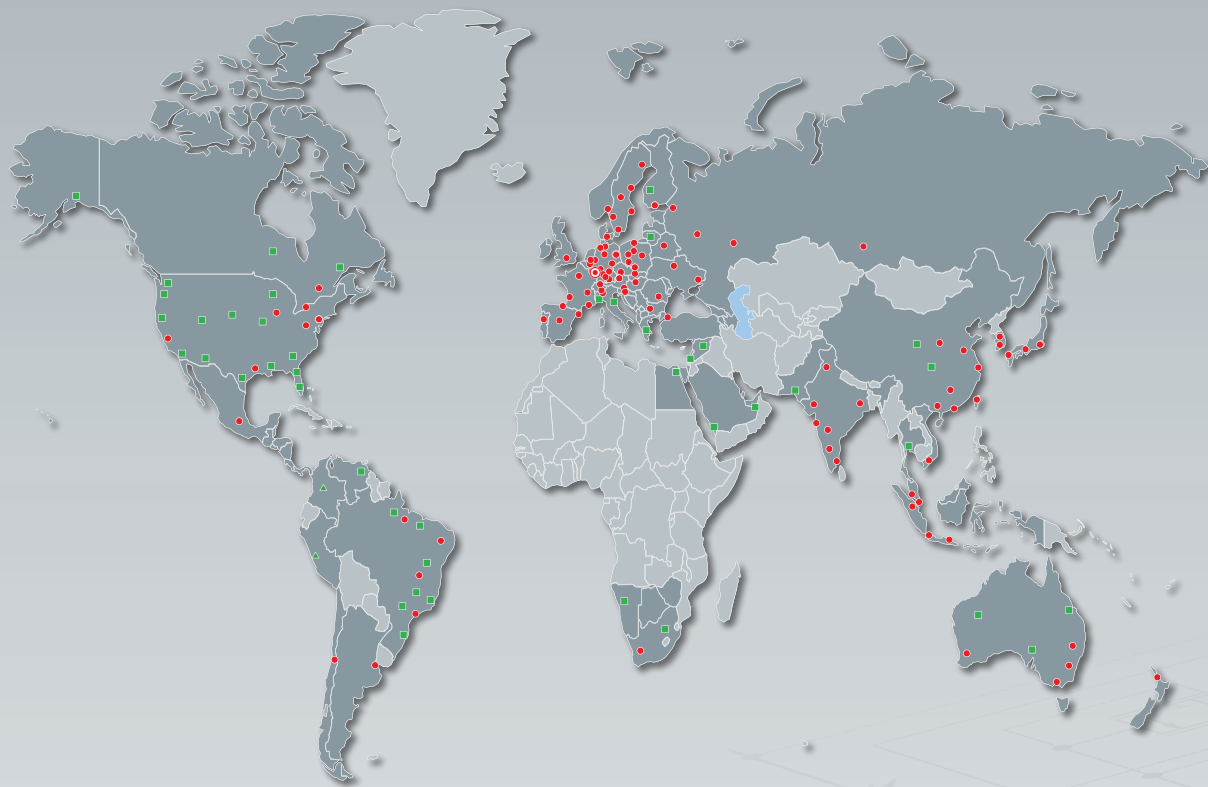

- HYDAC Headquarters
- HYDAC Companies
- HYDAC Sales and Service Partners
- Free Sales Partners

HYDAC INTERNATIONAL

HYDAC DRIVE CENTER
GmbH

Kiesgräble 13
89129 Langenau
Germany

Phone: +49 7345 93360-0
Fax: +49 7345 93360-4190

E-mail: antriebe@hydac.com
Internet: www.hydac.com